



DH2 SERIES

VIBRATING SCREENER

MANUAL

For

VIBRETTE

GREASE LUBRICATED DRIVES

IMPORTANT!

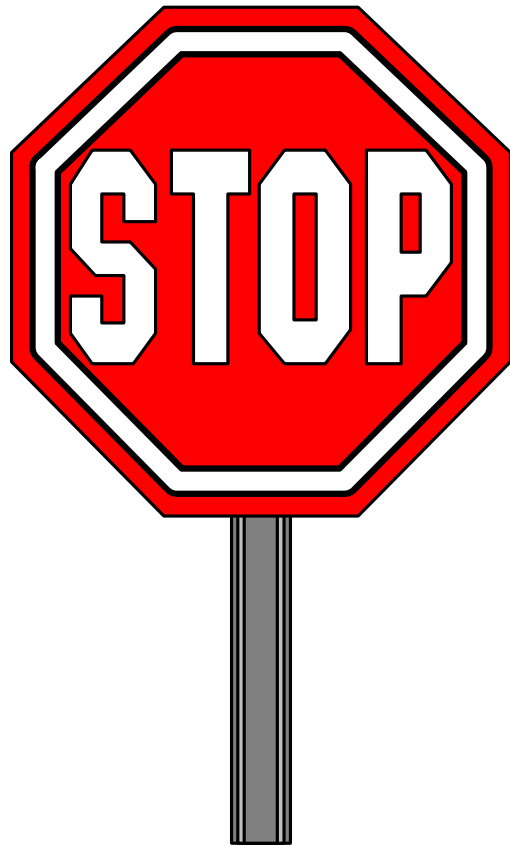

SCREENER STORAGE

Long Term Storage greater than 60 days may cause damage to vibrator drive components.

Please consult
SMICO Manufacturing
for storage instructions.

SMICO Manufacturing Co., L.L.C.
Oklahoma City, Okla. 73127
405-946-1461





IMPORTANT

Before operating your DH2 series screener, be sure to remove the transit bracket from the spring mounts. These brackets have been provided to minimize damage to the shaker while in transit. Failure to remove these brackets before operation of your screener could result in damage to the screener as well as the surrounding structure. Retain these brackets for use when moving or re-shipping the unit.

BEARING LUBRICATION

Before operating your DH2 series screener, be sure to review the lubrication section of this manual.

LAYUP PRIOR TO INSTALLATION



Should it be necessary to store your DH2 series screener more than 60 days after delivery, be sure to contact SMICO for long-term layup, and bearing preservation instructions.

FOUNDATIONS

One of the most important individual items for satisfactory operation of your DH2 series screener is the preparation of a proper foundation. The essential part of a foundation is that it is rigid and square.

Steel or concrete foundations are recommended. Wood foundations are not recommended since they are rarely rigid, and since they are subject to temperature changes and warpage, it is impossible to insure accuracy or squareness.

When selecting a steel foundation it is necessary that the beam is selected such that the natural frequency of the beam is not within the period of sympathetic vibration period of the machine.

The spring mounts on the machine provide vibration isolation for this machine. **DO NOT** attempt to further isolate this machine by using some type of vibration isolator between the frame and the foundation. This will result in a frame that is not rigid and the machine will vibrate this frame excessively. This will usually produce more vibration transmission rather than less vibration transmission.

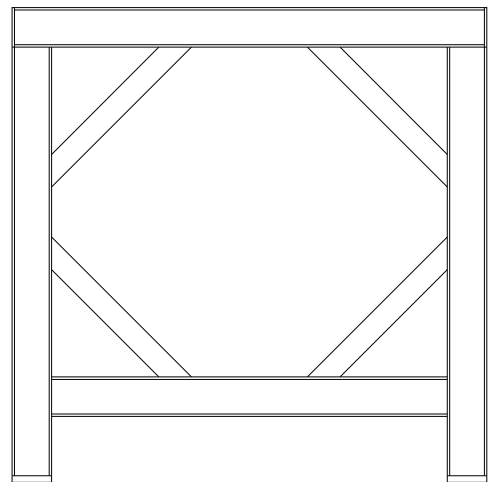

Typical frame depicting gussets that are properly sized and located. The traditional "x" bracing is not adequate for vibrating equipment.

HOPPERS

In erecting a hopper beneath the screen, be sure the valley angles are steep enough to give a free flow of the material being screened. See that the hopper is built low enough so the live machine structure will not strike the hopper, even when the machine is set at the steepest angle. Also note the screener will have random and erratic movement during start up and shut down. Allow an extra 2" around the live machine to allow for this movement.

DISCHARGE CHUTES

In designing discharge chutes the valley angles and clearances specified in the hoppers paragraph needs to be taken into account. In addition to that, the screens are removed from either end. This will require access to the end of the unit, and screen cloth removal will require the length of the screen panel beyond the machine.

If a dust seal is required, the use of flexible connectors is the best method of accomplishing this. This type of connector must be flexible enough to allow free movement of the live unit with out restrictions. NOTE: Flexible connectors which are stiff may cause excessive vibration transmission to the surrounding structure, damage the screener itself, and alter the screening efficiency.

FEED CHUTES

Feed chutes must also conform to the specifications specified in the hoppers paragraph. In addition to that feed chutes are an important part of the screener.

Feed chutes should provide of distribution of the material across the full width of the machine. Feed chutes should limit the fall of the material as much as possible. They should also slow up fast moving streams. These aspects will allow for efficient screening of your product. Proper feed chutes will adequately repay for the time spent constructing them by reducing screen cloth wear and increasing the efficiency.

CONTROL YOUR PRODUCT

Your DH2 series screener is fully adjustable to your product; Take full advantage of these exclusive features so you may obtain the most efficient results possible. Be sure the stroke, speed, and the angle of the machine are correct for your product. Do not guess! Check it!

BALANCE

SMICO DH2 series of screeners is dynamically balanced. Dynamically balanced means the weight of the machine is counter balanced by the rotating counter weights, on the counter weight wheels, to produce the vibrating effects that are uniform across the entire screen area. The loading of the machine effects this motion and dramatic surge loading of the machine could produce undesired effects.

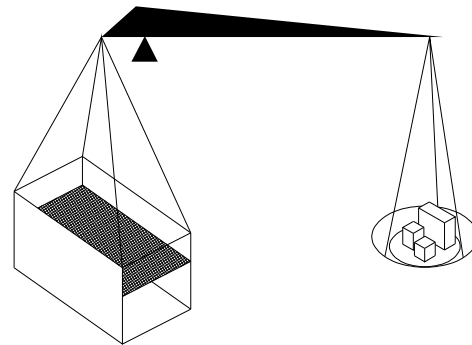

The weight of the machine is accurately counterbalanced. These counter weights are attached to the counter weight wheels, and are not to be changed unless additional weight is added to or removed from the machine. If weight is added or removed from the machine contact the factory for assistance in adding or subtracting counterweight. **NOTE: DO NOT** add skirt boards, wearing plates, chutes, feeders, or any other material to the live part of the machine. These structures will be subject to extreme dynamic forces and fatigue; In addition, they will change the balance of the screen. Such unbalance could cause serious problems such as premature bearing failure, destroying the motor, and transmitting excessive vibration to the structure.

ANGLE

The inclination at which the screening surface is operated plays an important part in the screening efficiency. If the angle is too great the material will pass over too rapidly, and will not be properly graded. If the angle is too slight efficient grading may not be maintained, the capacity of the screen will be reduced, and material will tend to accumulate at the feed end of the machine, causing undue wear and breakage of the screen cloth. Proper inclination of the screen provides efficient grading and capacity. Tests have indicated on some materials, a 5^o difference on inclination has caused a variation in recovery as great as 90%.

The deck construction or screen body is held in position by springs at each of the four corners of the machine. These springs should be vertical during operation. Consult the factory for more than minor changes in the inclination.

STROKE

The DH2 series of screeners vibrates in a vertical circular pattern. The diameter of this circle is called the stroke. The stroke can be measured in one of two ways. First, a dot can be placed on the side of the machine and the diameter of the dot makes when the machine is in operation is the stroke. Second, a stroke gauge can be used to determine the stroke.

A small stroke gauge is made up of a number of circles with specific diameters. One of those diameters must correspond to the stroke of the machine. The diameter of the circles corresponds to the number below the circle. When this gauge is placed on the side of a machine the circles will blur. There will be one blurred circle where the center-blurred circle is a black point. The diameter of that circle will be the stroke.

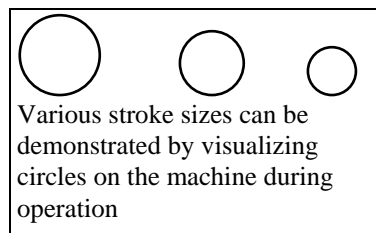

The stroke of the DH2 series of screeners can be changed by adding or removing counter weight that is laminated on the counter weight wheel. It is imperative that the two sides must have the same amount of counter weight. **NOTE:** Changes in the counter weight will cause changes in the stroke; This **stroke change requires a speed change**. Please refer to the section on speed for proper speed selection. Consult the factory for any dramatic changes in the operation of the equipment. Improper changes to the stroke and speed could result in severe damage to the machine.

SPEED

The speed plays an important part in screen operation within certain ranges. Discretion must be used in the selection of the speed-stroke combination. The tests carried out by independent organizations indicate that in general, speeds in excess of 1600 RPM have little effect on the efficiency or capacity of the screen.

SMICO screens operate at speeds from 800 - 1500 RPM, and they normally operate with strokes from 1/8" - 1/4". The speed is inversely related to the stroke for energy limits. For example:

1/8" stroke	1300 - 1600 RPM
3/16" stroke	1200 - 1300 RPM
1/4" stroke	1000 - 1200 RPM
3/8" stroke	800 - 1000 RPM

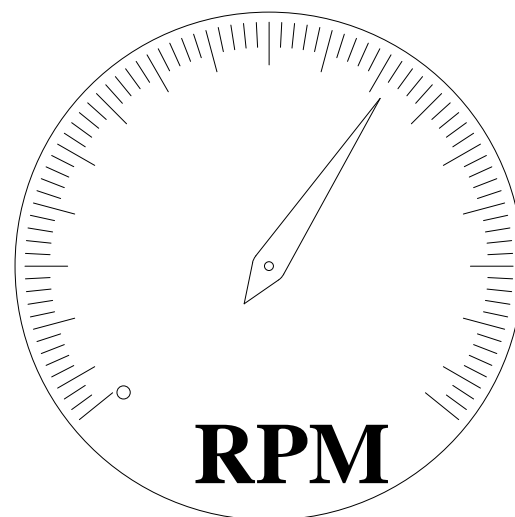

These machines should not be operated outside these limits. If the speed is too slow the machine will not operate at capacity; Yet if the speed is too great the bearings will become overloaded, which results in premature bearing failure.

Generally a stroke of 3/16 and a speed of 1250 RPM is efficient in screening most materials. In other cases a slower speed with larger stroke works well for larger size material, and faster speed with smaller stroke works well for smaller material.

Speed on a SMICO screen may be controlled in either of two ways. First, the speed can be controlled by using a variable speed motor or motor controller. Second, the speed can be changed by sheave selection. Single speed v-type sheaves are standard on SMICO screens. These sheaves are sized to give the speed our tests and experience indicates most desirable for the job.

SCREEN CLOTH SELECTION

Screen cloth selection is very important in order to obtain proper results, to eliminate screening problems, and to avoid costly maintenance and replacement. Screen cloth should be selected by considering three aspects.

FIRST:

The first aspect is maximum open area. When the open area is maximized, the capacity and efficiency of the screen are at their peak; however, the screen life is greatly reduced, and frequent replacement will be required. Decreasing the wire size used in making the screen cloth can increase the open area of a screen cloth.

SECOND:

The second aspect is maximum screen life. When screen life is at its maximum, the wire size of the screen is increased causing less frequent screen replacement, and fewer down times; however, when screen life is high the capacity of the screen is low. Increasing the wire size used in making the screen cloth can increase screen life in a screen cloth.

THIRD:

The third aspect is corrosion resistance. With a high corrosion resistant screen the screen will hold up longer from chemical materials such as water or acid; Yet, a screen with a high corrosion resistance is costly, and may be hard to locate, and have a long delivery schedules.

The hooks on the outside edges of the screen cloth should vary depending upon the wire diameter of the screen cloth. For lighter than 16 GA cloth the hooks need to be double bent sheet metal shrouds, to prevent the screen cloth from pulling loose when the screen cloth is tightened. Screen cloths from 16 GA to 8 GA wires need only a single fold sheet metal shroud. Wires heavier than 8 GA are strong enough to allow tensioning without any shroud.

In addition to this, specialty screens can be furnished for your particular needs. Some of these types of screens are perforated plate, slotted screens, music wire screens, flat top screens, synthetic screens, and many others. If you need further information on screen cloth selection consult the factory.

SCREEN CLOTH REMOVAL

1. Remove feed inlet and discharge end plates.
2. Loosen the tension bolts on each side. These are the bolts holding the tension rail that stretches the screen cloth. The nuts should be backed off sufficiently to allow easy sliding of screen hooks along the tension rail. (Be sure that ALL tension bolts have been loosened.)

3. Stand at the end of the machine and slide the screen out, pulling it squarely toward you. Care should be exercised that when the screen is almost all the way out, that it is held level until it's completely out. On heavy-gauge cloth, two persons may be required.

SCREEN CLOTH INSTALLATION

1. The inside of the screen body should be thoroughly washed or wiped clean. Be sure that all surfaces are free from debris and that there are no cuttings or other foreign material caught beneath the screen when it is installed.
2. Make sure tension rails are pulled out as far as the slack in the tension bolts will allow.
3. Now insert the new screen cloth. Start one side of the screen hook strips under the tensioning rail and slip it in slightly. Start the opposite side in the same manner and with the screen square; push it into the screener.
4. The screen is in place when the hook strips on the screen are flush with each end of the screener.
5. Hand tighten the four corner tensioning nuts so there is an equal amount of space between the hook strips and the wall of the screener on all four corners.
6. Tighten the remaining nuts hand tight.
7. Starting with the nuts in the CENTER of the tension rail and working out to the ends, slightly tighten two bolts on one side; then move to the corresponding two bolts on opposite side and tighten in equal proportions. Repeat process moving from the center to the ends until screen feels tight and even.
8. Check the cloth tightness by feeling of the cloth for loose spots. The screen cloth must be drum head tight. Life of the screen cloth and efficiency of separation depend on there being no loose areas in the cloth. Any loose spots must be removed by tightening the tension bolts in the vicinity of the loose spot. If this does not correct the problem consult the factory.
9. For lighter wire screen cloth, fold down the two ends of the screen. **DO NOT CREASE.** Fold the two corners of one end and bend the cloth at the corners sharply down against the end of the screener frame. Work from either side toward the center and pull the cloth as tight as possible to further tighten at ends.
10. Replace the end plates and the unit is ready for operation. Run the screener for about 30-40 minutes. Then stop the machine and re-tighten the tension bolts. This is important since the weave of the screen will allow it to take a certain set during the first few minutes of operation and will allow slack to develop in the screen.

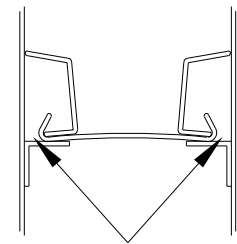

These distances must be equal

11. Again, re-tension after running 24 hours, as this will give greatly improved screen life.

BOLTS

All bolts on the screener are secured with lock washers or some other type of locking mechanism. After the machine has been in operation for two weeks it is wise to re-tighten the bolts to assure they are tight. Loose bolts break.

LUBRICATION

The DH2 series of screeners is a grease-lubricated drive. The recommended grease is a **lithium-based grease**, penetration class 2, with high additives and corrosion inhibitors. This **lithium based EP 2 grease** should not be blended with any other type of grease. The blending of greases of different alkylester bases is likely to result in a marked deterioration of lubricity and possible premature bearing failure.

The bearings of vibrating screens need to be re-lubricated every 50 hours of operation for normal duty operations. For higher temperature applications more frequent greasing is required. If the screener is in a hostile environment, the bearings will require more frequent re-lubrication. The amount of grease required at each re-lubrication for the DH2 series screener drive is 1oz.

The lubrication of a machine will directly affect the life of the bearing. Greasing too frequent will not harm the bearing; however, adding large quantities of grease at a time may have adverse effects.

BEARING REMOVAL

1. Disconnect the power to the motor. Tag out or lock out the motor while servicing.
2. Remove the belt guard and belt.
3. Remove the drive sheave and bushing from the shaft.
4. Remove the drive cover.
5. Remove the counter weight wheel (Item 6.) NOTE: The counter weights (Item 7) do not need to be removed to remove the counter weight wheel.
6. Remove the six hex head bolt (item 18) in the seal housing (Item 5).
7. Slip the outer seal housing off. The seal should remain in the seal housing. (Item 12) This seal needs to be checked for any nicks or cracks. If any nicks or cracks are present replace the seal before reassembly of the machine.

8. Remove the six hex head bolts (item 18) that hold the shaft housing (item 1) to the bearing housing (item 4).
9. Remove the six bolt assemblies (item 19) that bolt the bearing housing to the side sheet of the machine.
10. Slide the bearing bracket (item 4) and inner seal housing (item 3) off the shaft. There is a slip fit between the bearing and the shaft, and a press fit between the bearing and the bearing housing.
11. The bearing must be pressed out of the bearing housing.
12. Check the inner seal (item 11) for cracks and nicks, and replace if necessary.

BEARING INSTALLATION

1. When purchasing a bearing it is imperative that the full part number of the Bearing be identical. **These bearings** are vibratory duty bearings and **have special clearances**.
2. Before installing the bearing the bearing must be packed with grease.
3. To press the bearing into the bearing housing bolt the inner seal housing (Item 3) to the bearing housing to insure proper location of the bearing.
4. Press bearing making sure the bearing is square in the housing. NOTE: This can not be done with a hammer or other type of impact method; however the bearing can be packed in dry ice and allowed to cool. It will then slip into the bearing housing easily. NOTE: When this method is used, grease pack the bearing after it warms up to ambient temperature.
5. Reassemble the drive by reversing steps 1 through 12 above. NOTE: The bearing nut is only on the motor side of the drive.

INSTRUCTIONS FOR REPLACING AND ADJUSTING BELTS ON A PIVOTING MOTOR BASE FRAME

REFERENCE: MOTOR TENSIONING DRAWING (27083)

1. Make sure that the machine is empty of product before starting these procedures.
2. Disconnect the power to the motor. LOCK OUT OR TAG OUT the motor while servicing.
3. Back off the compression spring bolt, item 5 removing tension from the spring, item 14.
4. Loosen the four (4) motor bolts, item 7.
5. Back off the two (2) slide bar bolts, (motor tensioning bolts) item 6.
6. Inspect items 3, 4, 8, 9, 14 for wear. These items include the pivot shaft, the lube align bearings, the spring washers, and the tension spring. Also inspect the belt(s) and the sheaves. Refer to the replacement parts list for part numbers.
7. If needed, replace the belts, item 9, at this time. Use the same size belts as specified for the screener. Refer to the replacement parts list for size and part number.
8. Tension the two (2) slide bar bolts item: 6 until the motor support base, item 2, is parallel with the base frame item 1. (Refer to detail A). This will position the centerline of the motor shaft, (Refer to detail B) approximately 2 ½" to 3 ½" from the centerline of the pivot shaft, item 3. In this position the weight of the motor will keep the belt(s), item 9, snug against the sheaves. As a check, push down on the belt(s) and release. The motor and pivot base should follow and return, the belts should be snug from the weight of the motor.
9. Tighten the four (4) motor bolts, item 7.
10. Tighten the compression spring bolt, item 5, until the belts are snug. The belts should have about ½" to 1" deflection when depressed, (Refer to detail C).
11. Return the machine to service per appropriate procedure.
12. Start up the machine and watch for end play in the belts. As a check, verify the pivoting motor base is cycling uniformly. The pivot base should have approximately a plus/minus 1/8" throw. If there is too much throw or excessive noise is observed, apply additional tension to the compression spring, item 5 until the pivot base settles out.

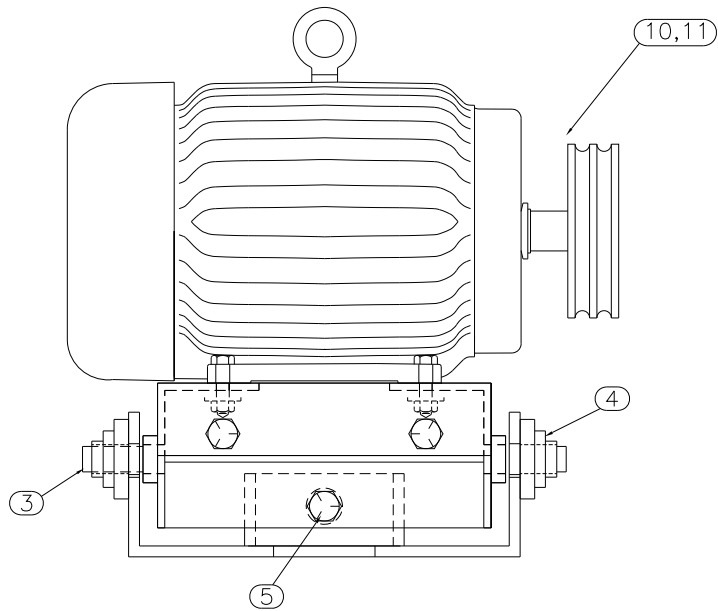
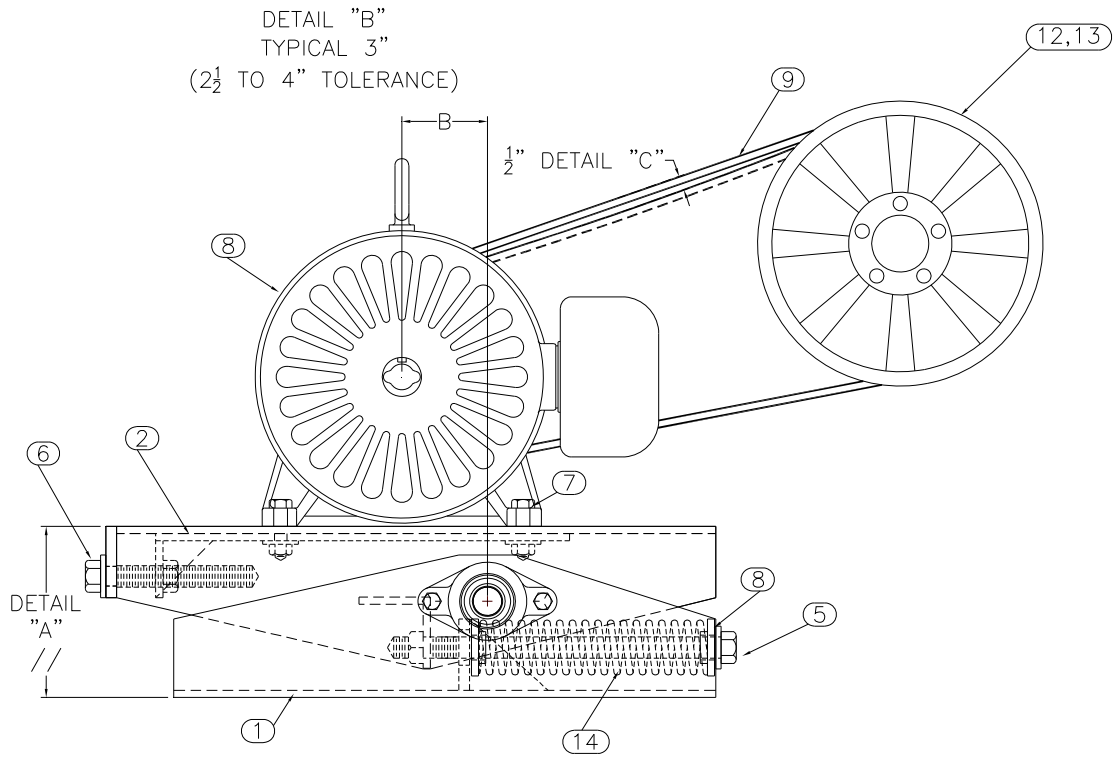

DRAWING 27083

DH2 DRIVE
VIBRETTE
510-SERIES 60mm

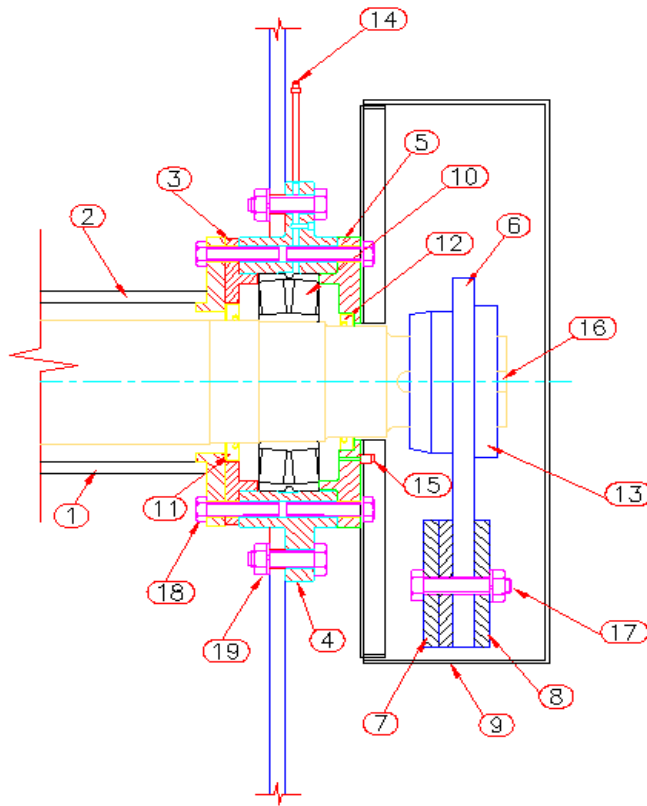

ITEM	QTY	DESCRIPTION	PRINT #	PART #
1	1	3' OR 4' SHAFT HOUSING	24181	510-302-300/400
2	1	3' OR 4' SHAFT	24170	510-301-300/400
3	2	UNIVERSAL BRG CVR (OPEN)	19182-3	430-314-001
4	2	BEARING HOUSING	20844	430-303-002
5	2	UNIVERSAL BRG CVR (OPEN)	19182-3	430-314-001
6	2	ECCENTRIC HUB	23632	510-307-001
7	2	INNER COUNTERWEIGHT	REF	REF
8	2	COUNTERWEIGHT	REF	REF
9	2	GUARD COVERS (DRIVE/BLIND)	23597	510-309-001/002
10	2	BEARING: 22312-HLSC3	22312	304-080
11	2	INNER SEAL	412040	314-150
12	2	OUTER SEAL	411394	314-140
13	2	TAPERLOCK BUSHING	2525-2 ¼	346-210
14	2	GREASE ZERK	1610BL	N/A
15	2	RELIEF FITTING ¼-1 PSI	REF	N/A
16	2	KEY	REF	N/A
17	6	½-13 X 2 HEX BOLT	REF	N/A
18	24	½-13 X 2 ½ HEX BOLT	REF	N/A
19	12	½-13 X 3 HEX BOLT ASSY	REF	N/A

DH2 DRIVE
VIBRETTE
525-SERIES 80mm

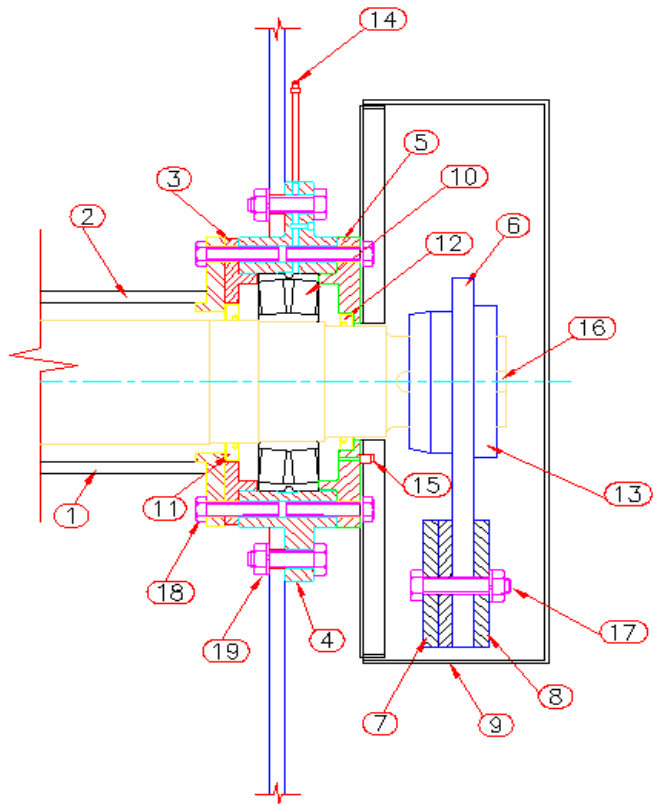

ITEM	QTY	DESCRIPTION	DRAWING NUMBER	PART NUMBER
1	1	SHAFT HOUSING 4' OR 5'	24135	530-302-400/500
2	1	SHAFT 4' OR 5'	27094	525-301-400/500
3	2	INNER SEAL RETAINER	27097	525-314-001
4	2	BEARING HOUSING	27095	525-303-002
5	2	OUTER SEAL RETAINER	27098	525-314-002
6	2	ECCENTRIC HUB	23635	530-307-001
7	2	INNER COUNTERWEIGHT	REF	REF
8	2	COUNTERWEIGHT	REF	REF
9	2	GUARD COVERS (DRIVE/BLIND)	23634	530-309-001/002
10	2	BEARING: 22316 EASK.MA.C4.F80	22317	304-085
11	2	INNER SEAL	415034	314-163
12	2	OUTER SEAL	416282	314-210
13	2	TAPER-LOCK BUSHING	3030-2 7/16	347-244
14	2	GREASE ZERK	1610 BL	REF
15	2	RELIEF FITTING ¼-1 PSI	REF	REF
16	2	KEY	REF	REF
17	6	½-13 X 2 HEX BOLT	REF	REF
18	24	½-13 X 2 ½ HEX BOLT	REF	REF
19	12	½-13 X 3 HEX BOLT ASSY	REF	REF

DH2 DRIVE
VIBRETTE
530-SERIES 85mm

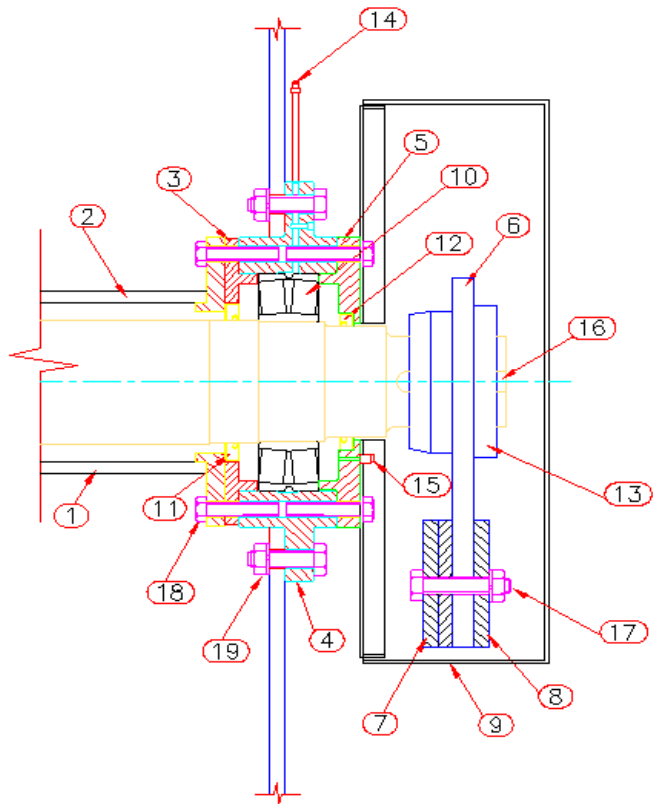

ITEM	QTY	DESCRIPTION	DRAWING NUMBER	PART NUMBER
1	1	SHAFT HOUSING 4' OR 5'	24135	530-302-400/500
2	1	SHAFT 4' OR 5'	23611	530-301-400/500
3	2	INNER SEAL RETAINER	19715	530-314-001
4	2	BEARING HOUSING	19714	530-303-002
5	2	OUTER SEAL RETAINER	23636	530-314-002
6	2	ECCENTRIC HUB	23635	530-307-001
7	2	INNER COUNTERWEIGHT	REF	REF
8	2	COUNTERWEIGHT	REF	REF
9	2	GUARD COVERS (DRIVE/BLIND)	23634	530-309-001/002
10	2	BEARING: 22317 EASK.MA.C4.F80	22317	304-090
11	2	INNER SEAL	415034	314-163
12	2	OUTER SEAL	416282	314-210
13	2	TAPER-LOCK BUSHING	3030-2 7/16	347-244
14	2	GREASE ZERK	1610 BL	REF
15	2	RELIEF FITTING ¼-1 PSI	REF	REF
16	2	KEY	REF	REF
17	6	½-13 X 2 HEX BOLT	REF	REF
18	24	½-13 X 2 ½ HEX BOLT	REF	REF
19	12	½-13 X 3 HEX BOLT ASSY	REF	REF

DH2 DRIVE
VIBRETTE
530- 1/2" "K" SERIES 85mm

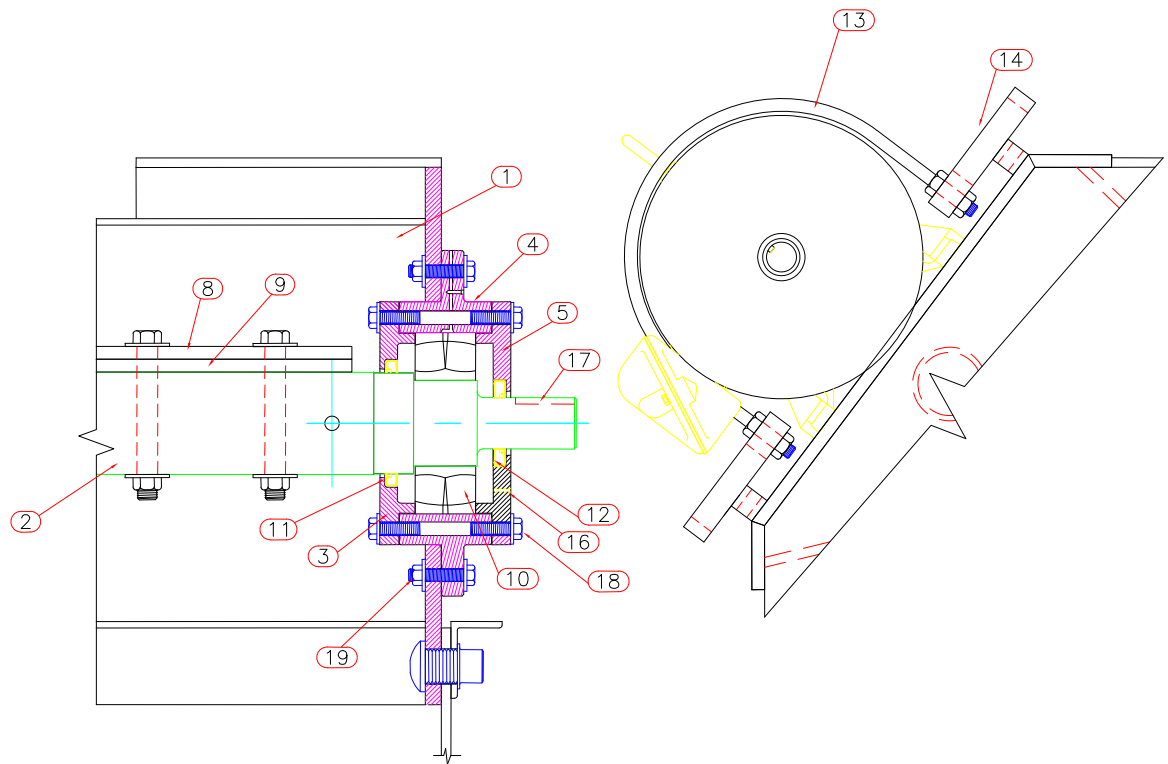

ITEM	QTY	DESCRIPTION	DRAWING NUMBER	PART NUMBER
1	1	DRIVE WELDMENT 4'	28094-RH/LH	530-302-4RK/4LK
2	1	SHAFT 4'	28095	530-301-40K
3	2	INNER SEAL RETAINER	19715	530-314-001
4	2	BEARING HOUSING	19714	530-303-002
5	1	OUTER SEAL RETAINER, OPEN	19716	530-314-K03
6	1	OUTER SEAL RETAINER, CLOSED	19716-X	530-314-K04
8	1	COUNTERWT, SMALL	28144-6	530-308-SMK
9	1	COUTNERWT, LARGE	28144-8	530-308-LGK
10	2	BEARING: 22317 EASK.MA.C4.F80	22317	304-090
11	2	INNER SEAL	415034	314-163T
12	2	OUTER SEAL	416282	314-110T
13	1	MOTOR CLAMP DOWN BAR	23006	23006
14	2	MOTOR CLAMP BAR ADJ PLATE	23007	23007
15	2	GREASE ZERK	1610 BL	C-9004
16	2	RELIEF FITTING 1/4-1 PSI	REF	C-9005
17	2	KEY	REF	530-307-003
18	24	1/2-13 X 2 HEX BOLT	REF	B-506
19	24	1/2-13 X 2 1/2 HEX BOLT	REF	B-508

DH2 DRIVE
VIBRETTE
550 SERIES 110mm

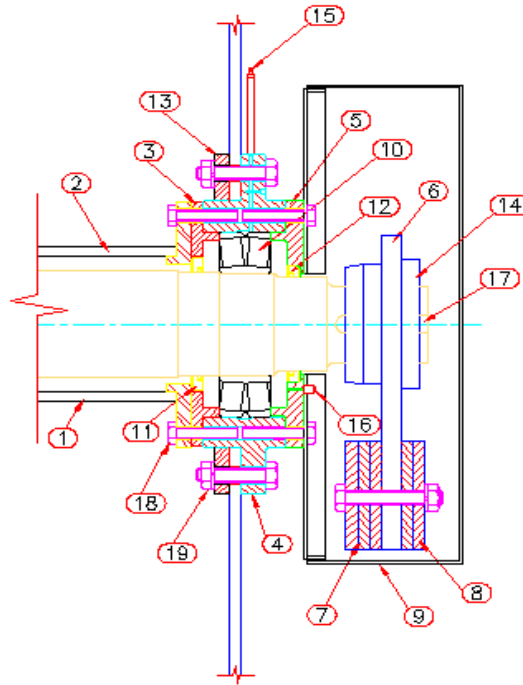

ITEM	QTY	DESCRIPTION	DRAWING #	PART #
1	1	SHAFT HOUSING 5' OR 6'	24076	550-302-500/600
2	1	SHAFT 5' OR 6'	24150	550/301/500/600
3	2	INNER SEAL HOUSING	24074	550-314-001
4	2	BEARING HOUSING/BRACKET	24072	550-303-002
5	2	OUTER SEAL HOUSING	24075	550-314-002
6	2	ECCENTRIC HUB	23635	530-307-001
7	2	INNER COUNTERWEIGHT	REF	REF
8	2	COUNTERWEIGHT	REF	REF
9	2	GUARD COVERS (DRIVE/BLIND)	24151	550-309-001/002
10	2	BEARING: 22222-EAS-MB-C3	22222	304-050
11	2	INNER SEAL	417-525	314-267
12	2	OUTER SEAL	416339	314-213
13	2	DRIVE REINFORCEMENT PLATE	24152	550-330-002
14	2	TAPER-LOCK BUSHING	3030 X 3 1/8	347-250
15	2	GREASE ZERK	1610BL	REF
16	2	RELIEF FITTING ¼-1 PSI	REF	REF
17	2	KEY	REF	REF
18	24	½-13 X 2 ½ HEX BOLT	REF	REF
19	12	5/8-11 X 3 HEX BOLT ASSEMBLY	REF	REF

DH2 DRIVE
VIBRETTE
560 SERIES HD 110mm

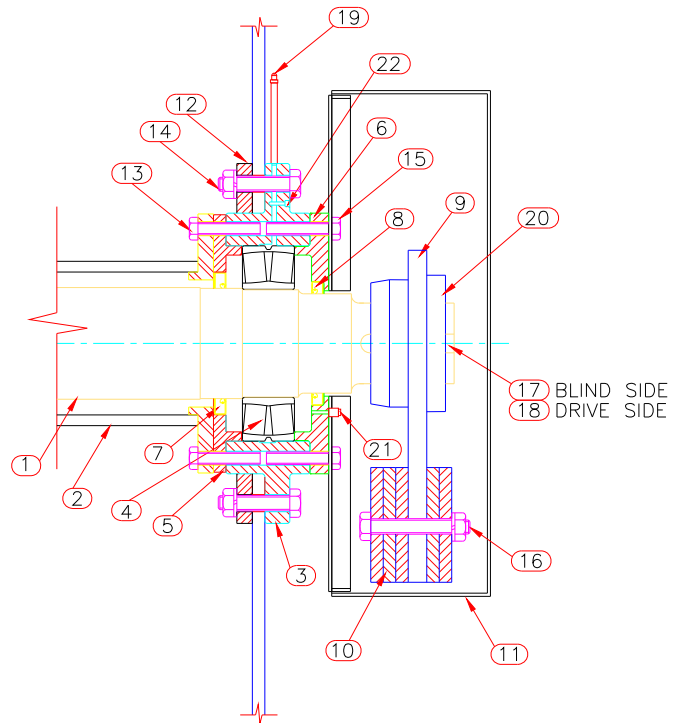

ITEM	QTY	DESCRIPTION	DRAWING #	PART #
1	1	SHAFT	25027	
2	1	SHAFT HOUSING	25026	
3	2	BEARING HOUSING/BRACKET	25023	
4	2	BEARING	23222-EAS-MB-C3	
5	2	INNER SEAL HOUSING	25025	
6	2	OUTER SEAL HOUSING	25024	
7	2	SEAL - INNER	417525	314-267
8	2	SEAL - OUTER	416339	314-213
9	2	ECCENTRIC WHEEL	23635	530-307-001
10	2	COUNTERWEIGHT	23638	
11	1 + 1	DRIVE COVERS (DRIVE/BLIND)	24151	550-309-001/-002
12	2	DRIVE REINFORCEMENT PLATE	24152	550-330-002
13	12	1/2-13 X 2 1/2 HEX BOLT	REF	REF
14	12	5/8-11 X 3 HEX BOLT ASSEMBLY	REF	REF
15	12	1/2-13 X 2 1/2 HEX BOLT	REF	REF
16	6	5/8-11 X 3 HEX BOLT ASSEMBLY	REF	REF
17	1	KEY - 3/4 X 3/4 X 3 3/4	REF	550-305-001
18	1	KEY - 3/4 X 3/4 X 8 1/4	REF	550-305-002
19	4	GREASE ZERK - 1/8 NPT	REF	REF
20	2	TAPER-LOCK - 3 1/8 BORE	3030	347-250
21	2	RELIEF FITTING 1/4-1 PSI	REF	317400
22	2	PIPE PLUG - 1/8 NPT	REF	REF