



SMICO  
3' X 6'  
SHALE SHAKER

MANUAL  
MODEL: 366-1CD-HHZ



**IMPORTANT!**

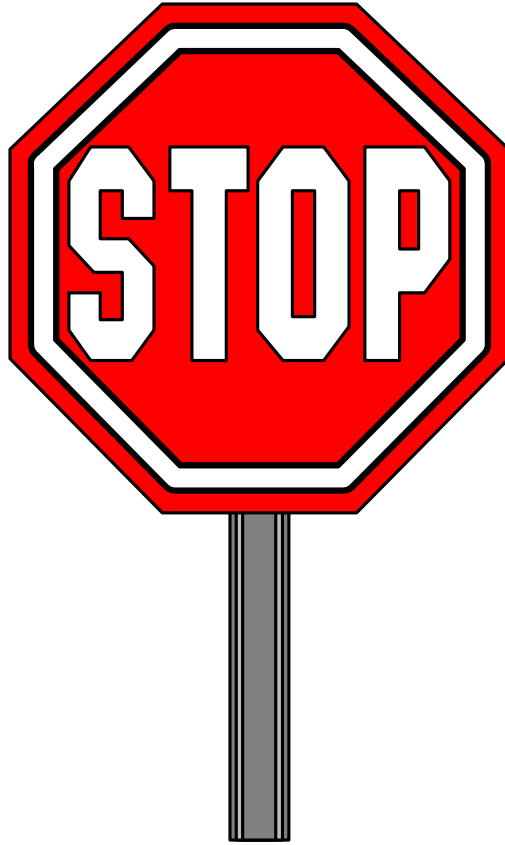

## **SCREENER STORAGE**

**Long Term Storage greater than  
60 days may cause damage to  
vibrator drive components.**

**Please consult  
SMICO Manufacturing  
for storage instructions.**

SMICO Manufacturing Co., Inc.  
Oklahoma City, Okla. 73127  
405-946-1461



# INSTRUCTIONS AND PARTS FOR SMICO SHALE SHAKER

## OPERATION

The primary function of the Shake Shaker is to remove the drilled solids from the weighted mud.

## DESCRIPTION

The SMICO Shale Shaker is a solids removal linear separator. The Shale Shaker is mounted onto a steel skid and consists of essentially four elements:

1. Weir Tank (possum belly w/wedge-type by pass)
2. Shaker Screen Basket
3. Skid with tank
4. Electrical (including motors and starters)

The SMICO Shaker is normally capable of screening 12 to 15 barrels of mud per minute. This figure will vary depending on the amount of solids in the mud, the type of mud and the temperature of the mud.

## INSTALLATION AND START-UP PROCEDURES

### 1. LOCATION

There are several possible locations for the SMICO Shaker on a rig.

- A. It may be set on the mud pit along side the rig shaker with a "y" connection installed from the rig flow line to the shaker, still leaving the rig shaker connected. When this is done, it is recommended that valves or other means of shutting off one or the other branch of the flow line be installed so that either the rig shaker, the SMICO Shaker, or both shakers may be operated as desired.
- B. The Shaker may replace the rig shaker. In this case the SMICO Shaker would be installed in place of the rig shaker.
- C. The SMICO Shaker may be set on the intermediate or suction pit and connections to it provided using the rig mud mixing system

The Shale Shaker should be located so that the outlet gates on one side or the other will deliver the screened mud into the pit or mud tank. When ever possible, the Shaker position would be such that these gates can be closed off and the gates on the opposite side opened. This allows flow from the shaker discharge pan over the side of the mud pit into the shale pit.

### 2. CONNECTION

The SMICO Shale Shaker is designed for a 10" inlet pipe in the surge tank. If the flowline or other inlet connection is a different size, it is intended that a suitable opening be cut out and a stub be welded to the surge tank. Connection can be made either by welding the assembly to the flow line or by using a dresser coupling.

### 3. LEVELING THE SHAKER

The shaking assembly should be adjusted level from side to side and from level to a slightly downward tilt or approximately 1/2" to 1" with the discharge end being lower.

### 4. TRANSIT BRACKETS

Loosen the Upper bolt on the transit bracket located on each rear two springs and swing the transit bracket away from the spring, then re-tighten the lower bolt. Do not discard the transit brackets. They are required to stabilize the vibrator unit each time the mud cleaner is moved.

## CONTROL YOUR PRODUCT

Your LINEAR series screener is fully adjustable to your product; Take full advantage of these exclusive features so you may obtain the most efficient results possible. Be sure the stroke, speed, and the angle of the machine are correct for your product. Do not guess! Check it!

## BALANCE

SMICO LINEAR series of screeners are dynamically balanced. Dynamically balanced means the weight of the machine is counter balanced by the rotating counter weights, on the shafts, to produce the vibrating effects that are uniform across the entire screen area. This motion is effected by the loading of the machine and dramatic surge loading of the machine could produce undesired effects.

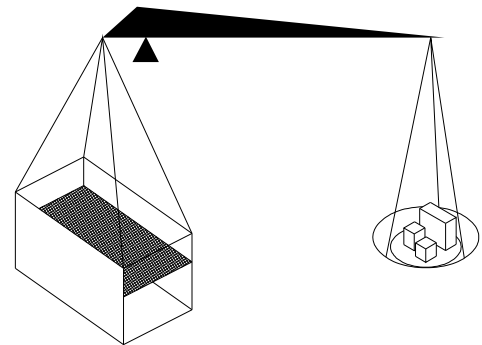

The weight of the machine is accurately counterbalanced. These counter weights are attached to the shafts, and are not to be changed unless additional weight is added to or removed from the machine. If weight is added or removed from the machine contact the factory for assistance in adding or subtracting counterweight. NOTE: DO NOT add skirt boards, wearing plates, chutes, feeders, or any other material to the live part of the machine. These structures will be subject to extreme dynamic forces and fatigue; In addition, they will change the balance of the screen. Such unbalance could cause serious problems such as premature bearing failure, destroying the motor, and transmitting excessive vibration to the structure, and other similar undesired effects.

## ANGLE

The inclination at which the screening surface is operated plays an important part in the screening efficiency. If the angle is too great the material will pass over too rapidly, and will not be properly separated. If the angle is too slight, efficient separation may not be maintained, the capacity of the screen will be reduced, and material will tend to accumulate at the feed end of the machine, causing undue wear and breakage of the screen cloth. Proper inclination of the screen provides efficient separation and capacity.

The deck construction or screen body is held in position by springs at each of the four corners of the machine. These springs should be vertical during operation. Consult the factory for more than minor changes in the inclination.

## AWD (Adjustable while drilling) ANGLE CONTROL



The deck angle can be adjusted from -1 degree to +5 degree with the manual operated hand wheel

## STROKE

The SMICO LINEAR Shale Shaker uses a rugged vibrator drive to impact a Linear vibration pattern. The Linear drive has been designed to produce a 3/16 stroke for optimum solids conveyance.

The stroke can be measured in one of two ways.

First, a dot can be placed on the side of the machine and the length of the line the dot makes when the machine is in operation is the stroke.

Second, a stroke gauge can be used to determine the stroke.

A small stroke gauge is made up of a number of circles with specific diameters. One of those diameters must correspond to the stroke of the machine. The diameter of the circles corresponds to the number below the circle. When this gauge is placed on the side of a machine the circles will blur. There will be one blurred circle where the two extreme circles come together in the middle at one point. The diameter of that circle will be the stroke.

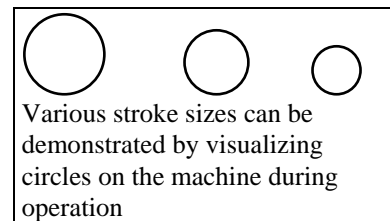

The stroke of the LINEAR series of screeners can be changed by adjusting the counter weight that is laminated on the shafts. It is imperative that the two shafts must have the same amount of counter weight. **NOTE:** Changes in the counter weight will cause changes in the stroke; this **stroke change requires a speed change**. Please refer to the section on speed for proper speed selection. **Consult the factory for any dramatic changes in the operation of the equipment.** Improper changes to the stroke and speed could result in severe damage to the machine.

## SPEED

The SMICO Linear Shale Shaker has been designed to operate at 1200 RPM for optimum solids conveyance and higher fluid capacity

## GENERAL INFORMATION

SMICO screens operate at speeds from 800 - 1500 RPM, and they normally operate with strokes from 1/8" - 1/4". The speed is inversely related to the stroke for energy limits. For example:

1/8" stroke	1300 - 1600 RPM
3/16" stroke	1200 - 1300 RPM
1/4" stroke	1000 - 1200 RPM
3/8" stroke	800 - 1000 RPM

These machines should not be operated outside these limits. If the speed is too slow the machine will not operate at maximum capacity; yet if the speed is too great the bearings will become overloaded, which results in premature bearing failure.

Generally a stroke of 3/16 and a speed of 1200 RPM is efficient in screening most materials. In other cases a slower speed with larger stroke works well for larger size material, and faster speed with smaller stroke works well for smaller material.

## SCREEN CLOTH SELECTION

Screen cloth selection is very important in order to obtain proper results, to eliminate screening problems, and to avoid costly maintenance and replacement. Screen cloth should be selected by considering three aspects.

### **FIRST:**

The first aspect is maximum open area. When the open area is maximized, the capacity and efficiency of the screen are at their peak; however, the screen life is greatly reduced, and frequent replacement will be required. The open area of a screen cloth can be increased by decreasing the wire size used in making the screen cloth.



## **SECOND:**

The second aspect is maximum screen life. When screen life is at its maximum, the life of the screen is increased causing less frequent screen replacement, and fewer down times; however, when screen life is high the capacity of the screen is low. Increasing the wire size used in making the screen cloth can increase the life of a screen cloth.

## **THIRD:**

The third aspect is corrosion resistance. With a high corrosion resistant screen the screen will hold up longer from chemical materials such as water or acid; Yet, a screen with a high corrosion resistance is costly, and may be hard to locate, and have a long delivery schedule.

The hooks on the outside edges of the screen cloth should vary depending upon the wire diameter of the screen cloth. For lighter than 16 GA cloth the hooks need to be double bent sheet metal shrouds, to prevent the screen cloth from pulling loose when the screen cloth is tightened. Screen cloths from 16 GA to 8 GA wires need only a single fold sheet metal shroud. Wires heavier than 8 GA are strong enough to allow tensioning without any shroud.

In addition to this, specialty screens can be furnished for your particular needs. Some of these types of screens are perforated plate, slotted screens, music wire screens, flat top screens, synthetic screens, and many others. If you need further information on screen cloth selection consult the factory.

## **SCREEN CLOTH REMOVAL**

1. Loosen the tension bolts on each side. These are the bolts holding the tension rail that stretches the screen cloth. The nuts should be backed off sufficiently to allow easy sliding of screen hooks along the tension rail or to allow the tee head bolt to disengage the tension rail. (Be sure that ALL tension bolts have been loosened.)
2. Stand at the end of the machine and slide the screen out, pulling it squarely toward you. Care should be exercised that when the screen is almost all the way out, that it is held level until it's completely out.

## **SCREEN CLOTH INSTALLATION**

1. The inside of the screen body should be thoroughly washed or wiped clean. Be sure that all surfaces are free from debris and that there are no cuttings or other foreign material caught beneath the screen when it is installed.
2. Make sure tension rails are pulled out as far as the slack in the tension bolts will allow, or insert the tee head bolt and turn 90°

3. Now insert the new screen cloth. Start one side of the screen hook strips under the tensioning rail and slip it in slightly. Start the opposite side in the same manner and with the screen square; push it into the screener.
4. The screen is in place when the hook strips on the screen are flush with each end of the screener.
5. Hand tighten the four corner tensioning nuts so that there is an equal amount of space between the hook strips and the wall of the screener on all four corners.
6. Tighten the remaining nuts hand tight.
7. Starting with the nuts in the CENTER of the tension rail and working out to the ends, slightly tighten two bolts on one side; then move to corresponding two bolts on opposite side and tighten in equal proportions. Repeat process moving from the center to the ends until screen feels tight and even.
8. Check the cloth tightness by feeling of the cloth for loose spots. The screen cloth must be drum head tight. Life of the screen cloth and efficiency of separation depend on there being no loose areas in the cloth. Any loose spots must be removed by tightening the tension bolts in the vicinity of the loose spot. If this does not correct the problem consult the factory.
9. Run the screener for about 30-40 minutes. Then stop the machine and re-tighten the tension bolts. This is important since the weave of the screen will allow it to take a certain set during the first few minutes of operation and will allow slack to develop in the screen.
10. Again, re-tension after running 24 hours, as this will give greatly improved screen life.

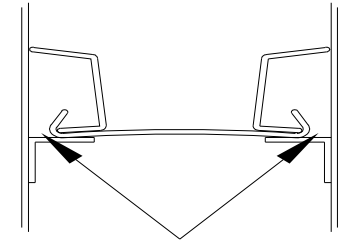

These distances must be equal

## BOLTS

All bolts on the screener are secured with lock washers or some other type of locking mechanism. After the machine has been in operation for two weeks it is wise to re-tighten the bolts to assure they are tight. Loose bolts break.

## MOTOR OPERATION SECTION

SMICO DUAL MOTOR SCREENERS are supplied with several sizes of vibrating motors depending on the size of the screener.

The motors will either be mounted on the sides the top or bottom of the unit depending the application requirements.

The following information is critical to all applications regardless of the size of the unit, motors or any other factor.

### MOUNTING BOLT TIGHTENING SEQUENCE:

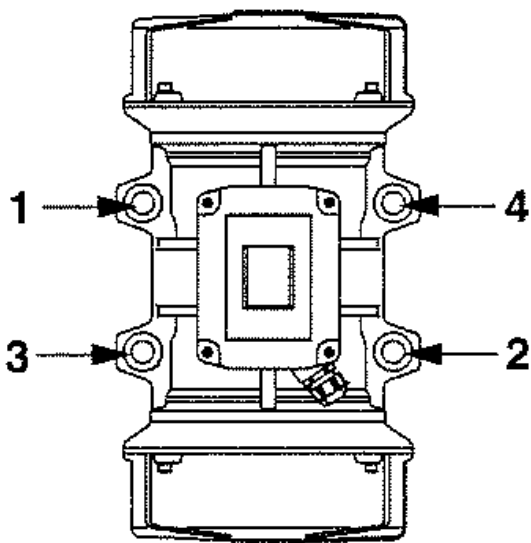

**4 Bolts**

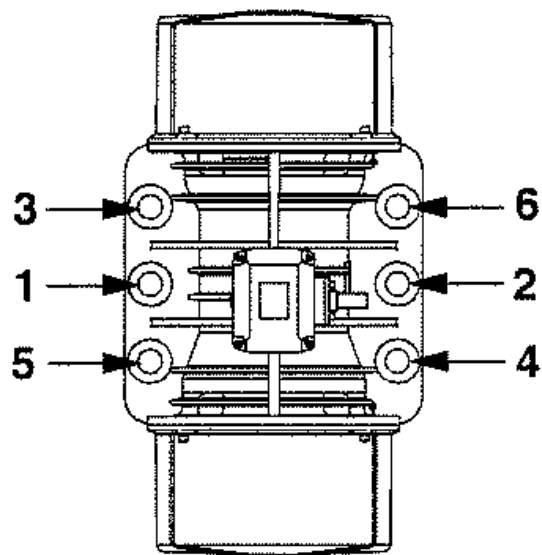

**6 Bolts**

### MOUNTING BOLT TORQUE REQUIREMENTS:

English		Metric	
Bolt Size (Gr 5)	Dry Torque (ft-lb)	Bolt Size	Dry Torque (kgm)
5/16 in. -18NC	17	M8	2
1/2 in. -13NC	76	M12	8
5/8 in. -11NC	137	M16	19
3/4 in. -10NC	288	M20	38
7/8 in. -9NC	430	M22	56
1 in. -8NC	644	M24	71
1 in. -8NC	644	M25	89

## SAFETY:

Before performing any maintenance or any of the prescribed operations on the motors: **LOCK OUT AND TAG OUT.**

## CHECK SHAFT ROTATION:

**This is very important and improper modifications can void the warranty on your vibrating screener, and/or drive components.**

- Remove the cap screws and washers and remove the vibrating motor end cap.
- DO NOT run the vibrating motors with the weights removed! This will damage the bearings.
- Check the rotation of the shafts (after power has been applied).
- Start the motors for one second and then stop.
- Observe the rotation of the motors. Again, for proper operation motors need to be turning in opposite directions.

**Keep hands away from the swinging weights. Weights can crush fingers and other body parts.**

**FROM THE FEED OR DISCHARGE END OF THE UNIT BOTH MOTORS ARE REQUIRED TO BE SIMULTANEOUSLY TURNING TOWARDS OR AWAY FROM EACH OTHER AND THE CENTER LINE OF THE UNIT.**

**PRODUCT WILL DICTATE ROTATION; HOWEVER THE MOTORS ARE REQUIRED TO BE TURNING OPPOSITE OF EACH OTHER!**

If this requirement is not met serious damage can be caused to the unit. The example below is one of the two options.

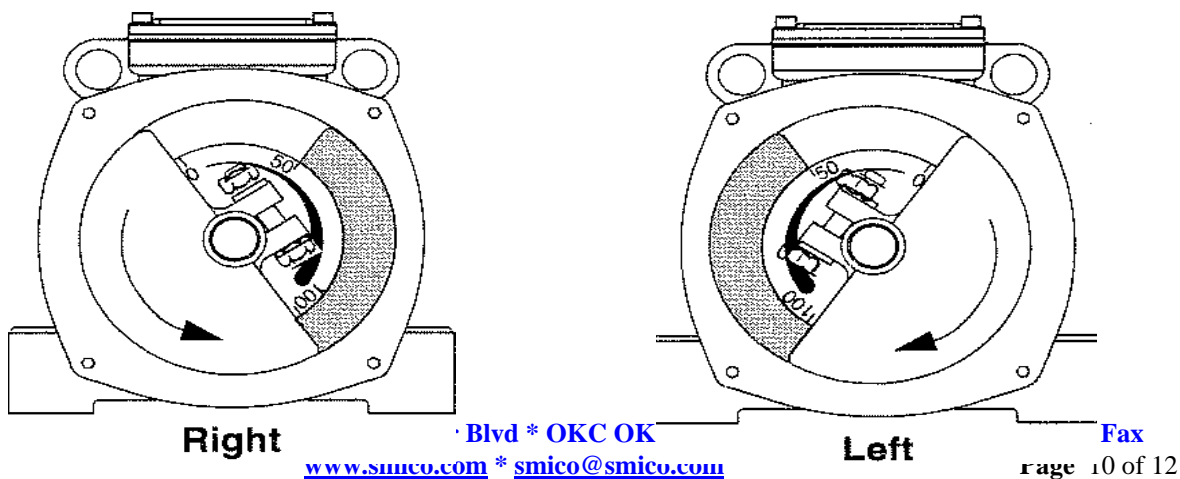

## **SMICO DUAL MOTOR SCREENERS REQUIRE THE THE MOTORS BE ELECTRICALLY INTERLOCKED.**

If using a single contactor, each motor must be provided with separate overload protection. The motor control circuit must be arranged so that if one motor becomes de-energized, the other motor will automatically and immediately become de-energized. Failure to properly interlock the motors could result in severe damage to the screener and other components if one of the motors fail.

### **ADJUSTING ECCENTRIC WEIGHTS:**

- The screener is shipped with the original engineering information that was acquired during the order process.
- Changes due to product, capacity, etc. may be required.

**It is strongly suggested that the customer contact SMICO for recommendations. Failure to do so may void your warranty.**

If it is required to adjust the eccentric weights in order to accomplish your screening needs, the following procedures should be followed.

- **Before adjusting eccentric weights, turn off and lock out/tag out energy to the screener!**
- Remove both end caps.
- Loosen the nuts or screws so the outer adjustable weights will rotate around the shaft. (the inner weight is fixed to the motor shaft).
- There will be increments that are easily identifiable on the weights; 0 thru 100%.
- **The motor weights on both ends of the motor shaft are required to be on the same setting.**
- Ensure that the settings need to mirror each other.

**PLEASE SEE DIAGRAMS BELOW:**

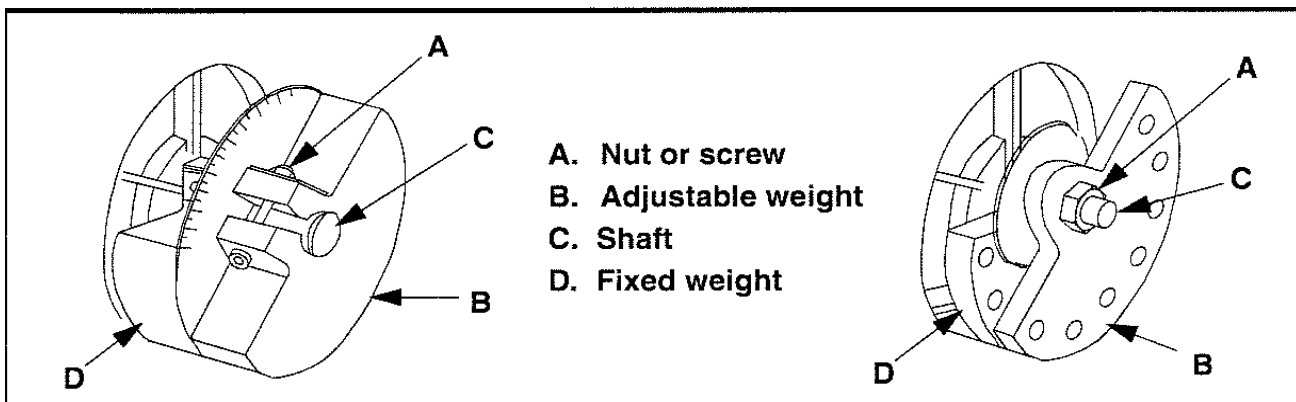

Adjusting the eccentric weights:

Setting sets of eccentric weights to mirror images:

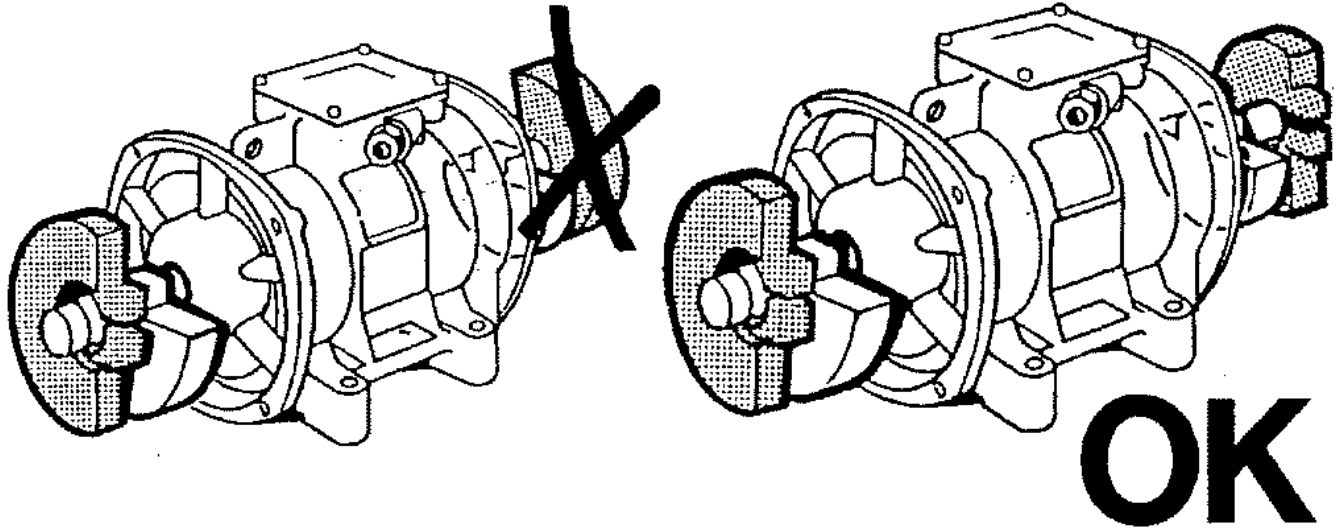

**AS ALWAYS, PLEASE CONTACT THE FACTORY FOR ANY CHANGES THAT MAY BE REQUIRED. WE ARE HAPPY TO HELP AND WILL ENSURE THAT YOUR EQUIPEMENT OPERATES AT OPTIMUM CAPACITY.**