

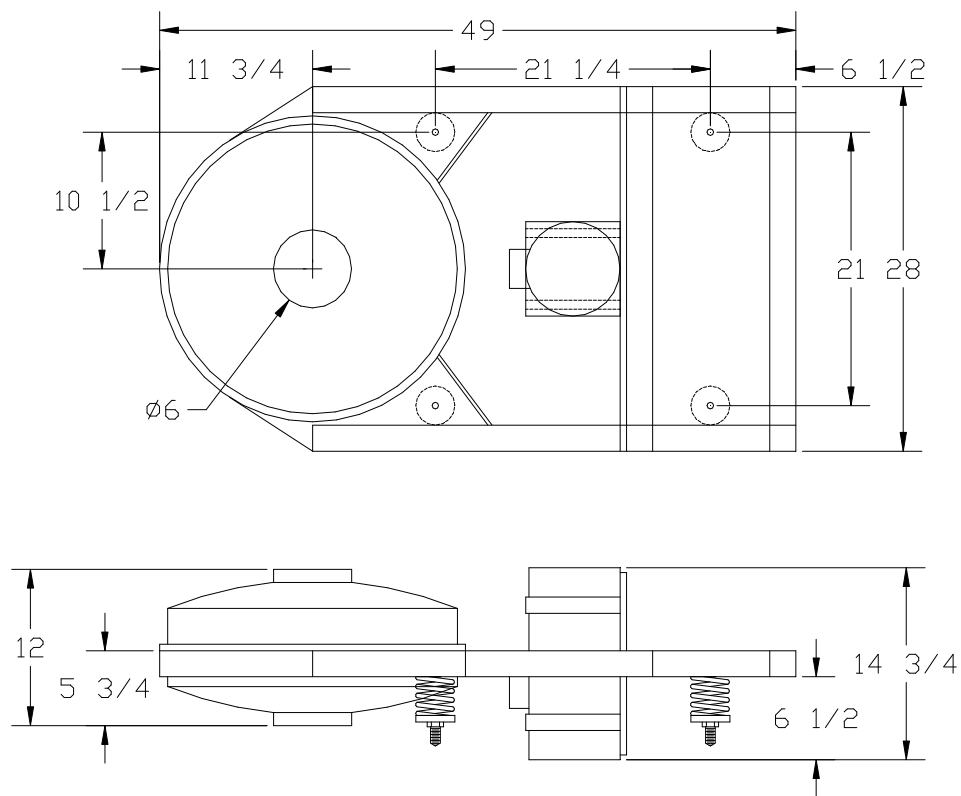

24" Flow Through

Operating Manual





30" Flow Through

Operating Manual

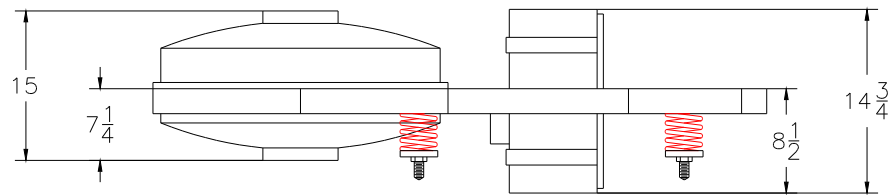
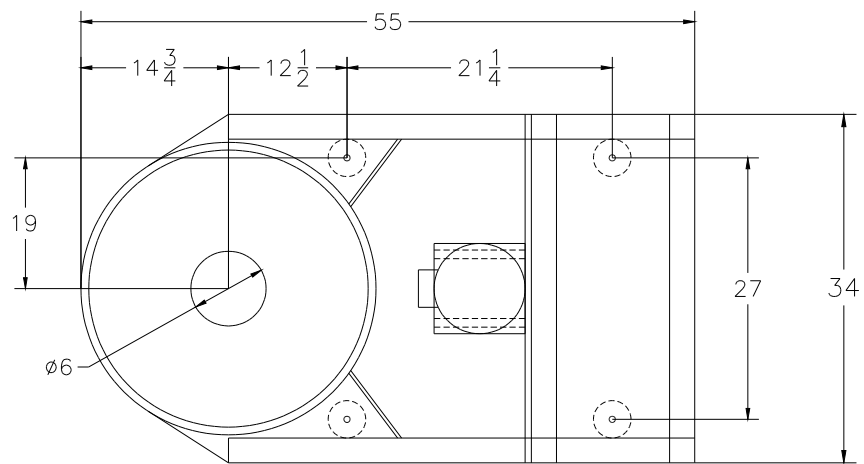



40" Flow Through

Operating Manual

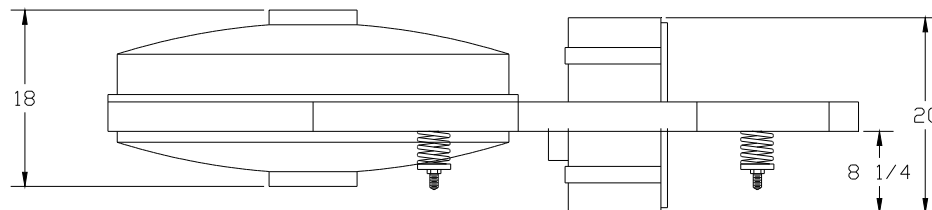
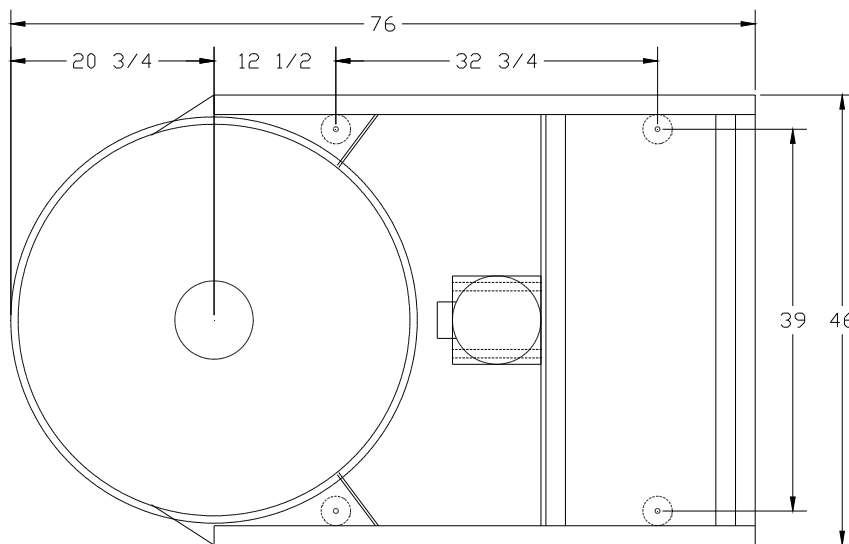

General

In general the FLOW THROUGH SIFTER is used when all of the product goes through the screen, and the machine is intended to catch the unusual oversize piece. This machine has no provision for the removal of these oversize particles short of dismantling of the machine. If the product in question has a significant amount of oversize particles this machine will blind over, and become ineffective in screening the good product. If this is the case either more frequent cleaning of the screen will need to be accommodated, or arrangements should be made with the factory for the purchase of another line of screeners which will accommodate significant amounts of oversize particles.

Foundations

The typical FLOW THROUGH SIFTER is cable hung from the ceiling, or other overhead structure. The FLOW THROUGH SIFTER comes with a cable suspension kit, which includes the following:

- 4 eye bolts
- 4 shackles
- 8 wire rope thimbles
- 8 wire rope clamps
- 1 50 foot of wire rope

These materials can be supplemented by some acceptable alternatives; however, SMICO recommends using the cable suspension kit unless this cable suspension can not be facilitated. The FLOW THROUGH SIFTER weighs approximately 150 lbs. The material which will be in the machine at any one time will vary depending on the material, but can be assumed to be less than 50 lbs. The follow through sifter operates at a frequency of 1800 cycles per minute. The supporting structure which will support the FLOW THROUGH SIFTER must be strong enough to support the 200 lbs live load, and not have a natural frequency which is a multiple of 1800 cycles per minute.

The cable kit should be installed such that the cables are vertical and not longer than 10 feet long. During the start up and shut down of this machine, the FLOW THROUGH SIFTER will move more than under normal circumstances. A 2" allowance around the machine should be allowed for this extra movement. In addition to the extra movement, the FLOW THROUGH SIFTER requires frequent disassembly and cleaning. Access to this machine for this reason will also be advantageous.

Disassembly

The disassembly of the FLOW THROUGH SIFTER should be done as follows: First, loosen the hose clamp from the inlet flexible connector. Slide this flexible connector off until it is free from the connection. Second, undo the band clamp around the middle of the machine, and loosen it so that the top portion may be removed. At this time, the top section may be lifted out of place exposing the screen cloth. The screen cloth may be cleaned off here, or it may be necessary to lift out the screen cloth to better accommodate cleaning it. If the lower section needs to be removed, the bottom flexible connector may be removed, followed by loosening the 'T' bolt on one side of the carbon frame. This will allow the lower section to be removed.

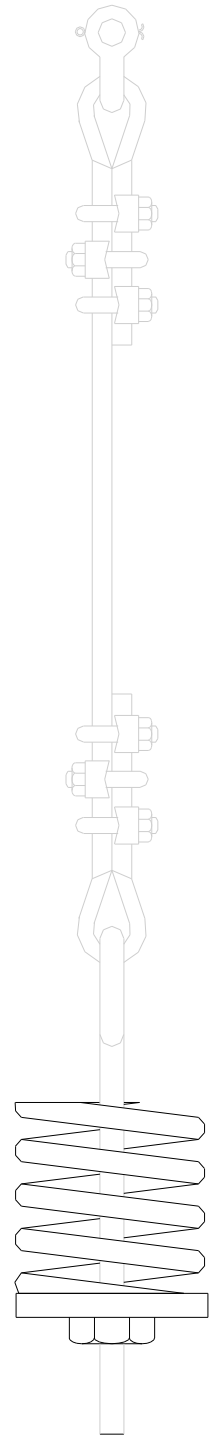

Assembly

The assembly of the FLOW THROUGH SIFTER is as simple as the disassembly is. First, place the bottom saucer into the frame, and clamp the two together using the 'T' bolt. Second, place the screen on top of the saucer so that it fits into place, followed by placing the top saucer directly on top of the screen. Then, fit the band clamp around the two saucers at the flange. Tighten the band clamp, and check for any loose parts. If there are no loose parts, reinstall the flexible connectors, tighten the hose clamps, and test the machine.

Motor

The motor on the FLOW THROUGH SIFTER is a shaker motor. This motor has an operating temperature range of -20°F to 104°F. The motor operates at 1800 cycles per minute, and has a variable stroke. This motor does not have any serviceable parts. If this motor fails for any reason contact SMICO for a replacement. When replacing this motor use only 1/2" grade 5 bolts. Torque these bolts down to 100ft-lb, and **do not** reuse the bolts.

Wiring

Note: All wiring should be done to the National Electric Code Handbook specifications, and should be done by a certified electrician.

Wiring diagrams for this motor are included inside the terminal block of the motor. Wire the motor according to the voltage available. This motor must be grounded. This machine shakes at a large enough movement that the metal flexible conduits will eventually break, and are not acceptable to be used under these circumstances. A flexible coated wire must be used here.

Overload protection must be installed. If the motor is operated without overload protection, damage to the motor will result, and the warranty will be void. The overload protection must be according to NEC article 430.

Once the motor is operating, check the amperage reading. The amperage reading should not exceed the motor name plate reading.

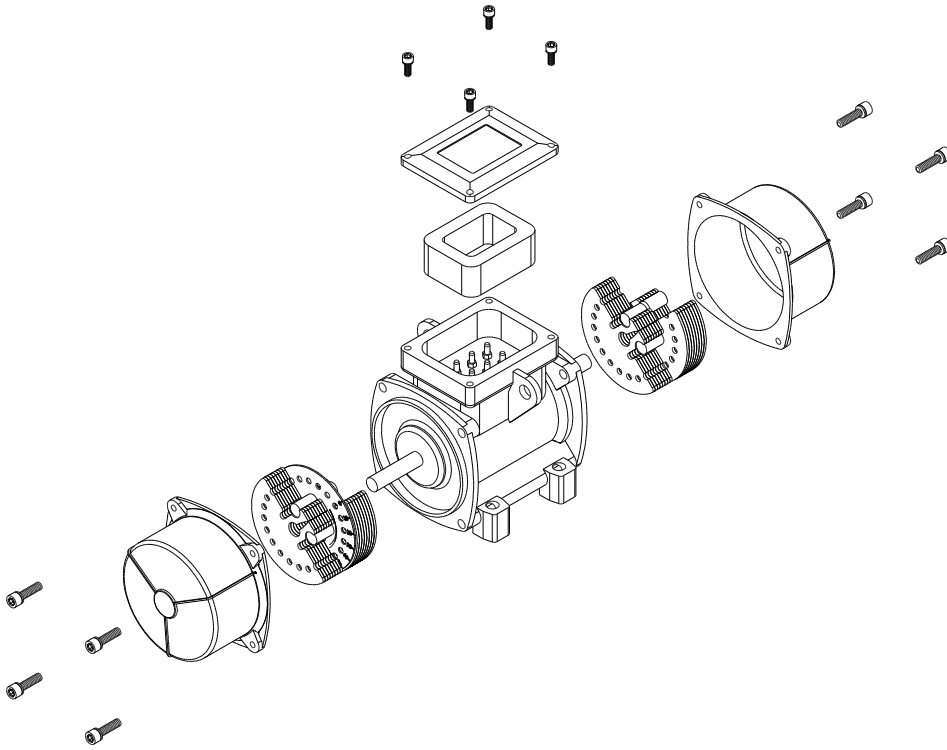

Adjusting the Motion

If the motion of the FLOW THROUGH SIFTER needs to be adjusted to accommodate the screening needs, follow the directions which follow. When adjusting the motion, it is necessary to adjust the eccentric weights in the motor. When working on the motor, it is necessary to lock out/tag out the energy source. Once the energy source is tagged out/locked out, remove the end caps on both ends of the motor. Note: it is important that both ends are adjusted exactly the same. Otherwise damage to the motor will result. Loosen the nut on top of the outside set of eccentric weights, and rotate the set of eccentric weights to the desired setting. For example: To increase the movement move the weights to a higher setting. For a gentler motion move the weights to a lower setting. Then set the other set of weights on the same setting. The optimum setting for this motor is the minimum setting at which will produce the screening desired.

Lubrication

The motor on the FLOW THROUGH SIFTER uses sealed for life bearings, which do not require re-lubrication. These bearings are not available through normal sources. DO NOT attempt to replace damaged bearings. Contact SMICO for a replacement motor.