

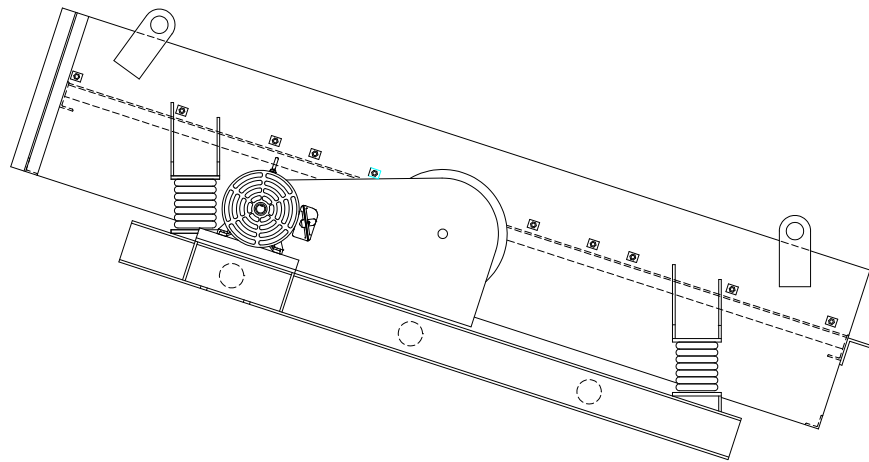

DH1 SERIES
VIBRATING SCREENERS
MANUAL
FOR
GYRETTE
GREASE LUBRICATED DRIVES

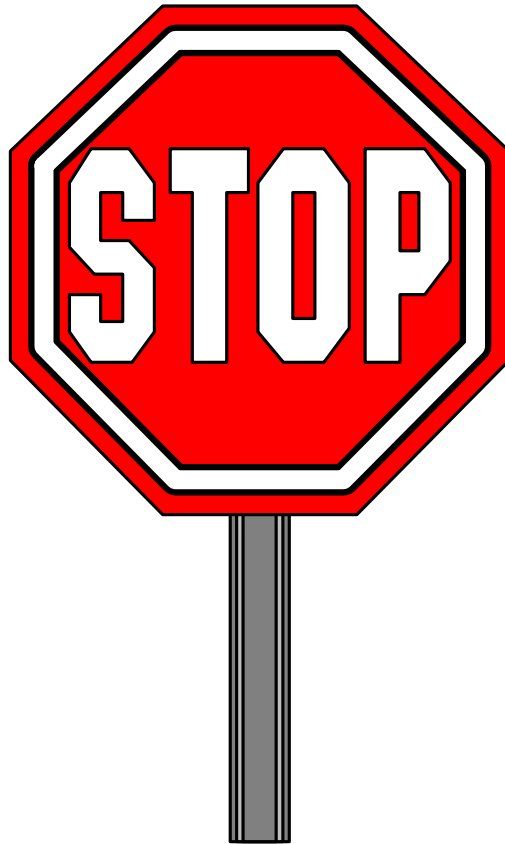

IMPORTANT!



SCREENER STORAGE

**Long Term Storage greater than
60 days may cause damage to
vibrator drive components.**

**Please consult
SMICO Manufacturing
for storage instructions.**

SMICO Manufacturing Co., Inc.
Oklahoma City, Okla. 73127
405-946-1461



IMPORTANT

Before operating your DH1 series screener, be sure to remove the transit bracket from the spring mounts. These brackets have been provided to minimize damage to the shaker while in transit. Failure to remove these brackets before operation of your screener could result in damage to the screener as well as the surrounding structure. Retain these brackets for use when moving or re-shipping the unit.

LAYUP PRIOR TO INSTALLATION



Should it be necessary to store your DH1 series screener more than 60 days after delivery, be sure to contact SMICO for long-term layup, and bearing preservation instructions.

FOUNDATIONS

One of the most important individual items for satisfactory operation of your DH1 series screener is the preparation of a proper foundation. The essential part of a foundation is that it is rigid and square.

Steel or concrete foundations are recommended. Wood foundations are not recommended since they are rarely rigid, and since wood is subject to temperature changes and warpage, it is impossible to insure accuracy or squareness.

When selecting a steel foundation it is necessary that the beam is selected such that the natural frequency of the beam is not within the period of sympathetic vibration wavelength of the machine. One inch of beam depth per foot of length span is usually adequate.

The spring mounts on the machine provide vibration isolation for this machine. **DO NOT** attempt to further isolate this machine by using some type of vibration isolator between the frame and the foundation. This will result in a frame that is not rigid and the machine will vibrate this frame excessively. This will usually produce more vibration transmission rather than less vibration transmission.

HOPPERS

In erecting a hopper beneath the screen, be sure the valley angles are steep enough to give a free flow of the material being screened. See that the hopper is built low enough so the live machine structure will not strike the hopper, even when the machine is set at the steepest angle. Also note the screener will have random and erratic movement during start up and shut down. Allow an extra 3" around the live machine to allow for this movement.

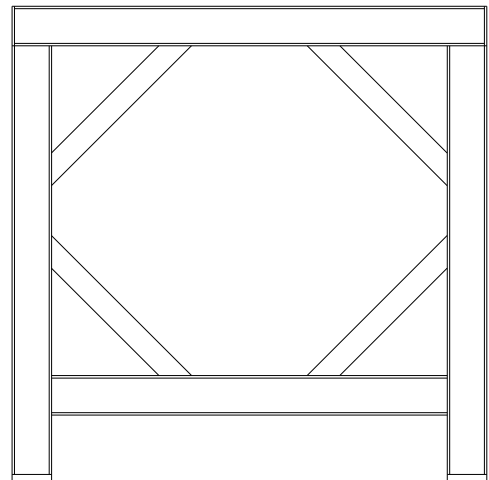

Typical frame depicting gussets that are properly sized and located. The traditional "x" bracing is not adequate for vibrating equipment.

DISCHARGE CHUTES

In designing discharge chutes, the valley angles and clearances specified in the hoppers paragraph need to be taken into account. In addition to that, the screens are removed from either end of the machine. This will require access to the end of the unit, and screen cloth removal will require the length of the screen panel beyond the machine.

If a dust seal is required, the use of flexible connectors is the best method of accomplishing this. This type of connector must be flexible enough to allow free movement of the live unit with out restrictions. NOTE: Flexible connectors, which are stiff, may cause excessive vibration transmission to the surrounding structure, damage the screener itself, and alter the screening efficiency.

FEED CHUTES

Feed chutes must also conform to the specifications noted in the hoppers paragraph. In addition to that feed chutes are an important part of the screener.

Feed chutes should provide distribution of the material across the full width of the machine. Feed chutes should limit the fall of the material as much as possible. They should also slow down fast moving streams. These aspects will allow for efficient screening of your product. Proper feed chutes will adequately repay for the time spent constructing them by reducing screen cloth wear and increasing the efficiency.

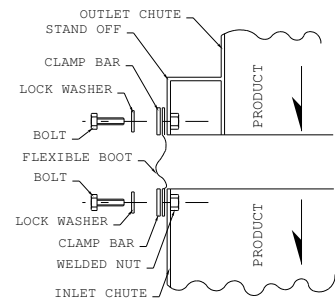

Rectangular boot connection with clamp bars and fasteners

CONNECTIONS

The connections between the DH1 and the matching chute work needs to be via a flexible connector. The distance between the two spouts needs to be 2 - 3 inches. This distance allows the machine the room necessary for start up and shut down. The connection between the two needs to be a flexible connector held in place by clamps. On a rectangular spout, the boot is held on by a clamp bar with bolts and welded nuts on the inside of the spout. On a round or elliptical spout, a hose clamp type fastener is all that is needed to hold the boot in place.

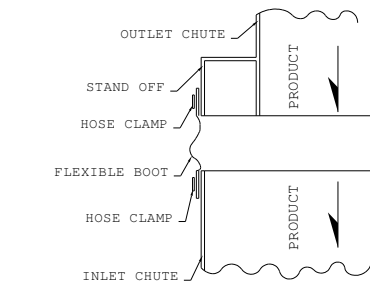

Round or elliptical boot connection with hose clamp

For abrasive applications, it is necessary to have a stand off between the spouts and the boots. This stand off will insure the product does not come in contact with the boot, preventing the product from prematurely wearing out the boot.

CONTROL YOUR PRODUCT

Your DH1 series screener is fully adjustable to your product; Take full advantage of these exclusive features so you may obtain the most efficient results possible. Be sure the stroke, speed, and the angle of the machine are correct for your product. Do not guess! Check it!

BALANCE

SMICO DH1 series of screeners are dynamically balanced. Dynamically balanced means the weight of the machine is counter balanced by the rotating counter weights, on the eccentric wheels, to produce the vibrating effects that are uniform across the entire screen area. The loading of the machine effects this motion and dramatic surge loading of the machine could produce undesired effects.

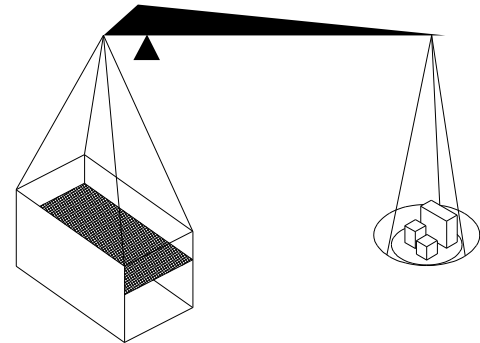

The weight of the machine is accurately counterbalanced. These counter weights are attached to the eccentric wheels, and are not to be changed unless additional weight is added to or removed from the machine. If weight is added or removed from the machine, contact the factory for assistance in adding or subtracting counterweight. **NOTE: DO NOT** add skirt boards, wear plates, chutes, feeders, or any other material to the live part of the machine. These structures will be subject to extreme dynamic forces and fatigue. In addition, they will change the balance of the screen. Such unbalance could cause serious problems, such as premature bearing failure, destruction the motor, and transmitting excessive vibration to the structure.

ANGLE

The inclination at which the screening surface is operated plays an important part in the screening efficiency. If the angle is too great, the material will pass over too rapidly, and will not be properly graded. If the angle is too slight, efficient grading may not be maintained, the capacity of the screen will be reduced, and material will tend to accumulate at the feed end of the machine, causing undue wear and breakage of the screen cloth. Proper inclination of the screen provides efficient grading and capacity. Tests have indicated on some materials, a 5^o difference on inclination has caused a variation in recovery as great as 90%.

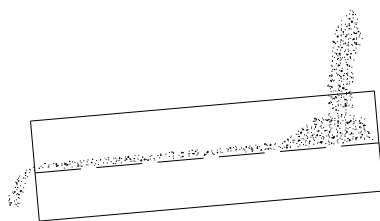

Angle too slight

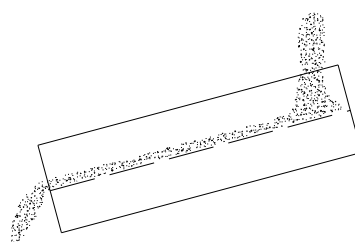

Proper angle

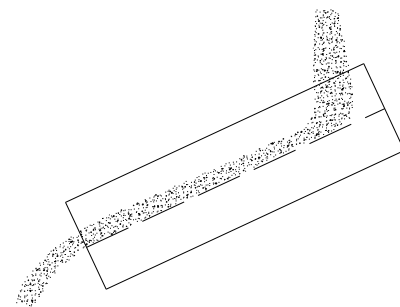

Angle too great

The deck construction or screen body is held in position by springs at each of the four corners of the machine. These springs should be vertical during operation. Consult the factory for more than minor changes in the inclination.

STROKE

The DH1 series of screeners vibrates in a gradient circular pattern. The diameter of this circle is called the stroke. The stroke can be measured in one of two ways. First, a dot can be placed on the side of the machine and the diameter the dot makes when the machine is in operation is the stroke. Second, a stroke gauge can be used to determine the stroke.

A small stroke gauge is made up of a number of circles with specific diameters. One of those diameters must correspond to the stroke of the machine. The diameter of the circles corresponds to the number below the circle. When this gauge is placed on the side of a machine the circles will blur. There will be one blurred circle where the center-blurred circle is a black point. The diameter of that circle will be the stroke.

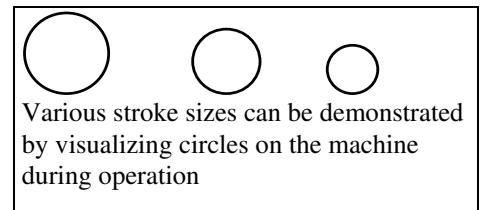

The stroke of the DH1 series of screeners can be changed by adding or removing counter weight that is laminated on the eccentric wheels. It is imperative that the two sides must have the same amount of counter weight. **NOTE:** The DH1 series of screeners is dynamically balanced, and changing the stroke of the machine will unbalance this machine. Also, changes in the counter weight will cause changes in the stroke. This **stroke change requires a speed change**. Please refer to the section on speed for proper speed selection. Consult the factory for any dramatic changes in the operation of the equipment. Improper changes to the stroke and speed could result in severe damage to the machine.

SPEED

The speed plays an important part in screen operation within certain ranges. Discretion must be used in the selection of the speed-stroke combination. The tests carried out by independent organizations indicate that in general, speeds in excess of 1600 RPM have little additional effect on the efficiency or capacity of the screen.

SMICO screens operate at speeds from 800 - 1500 RPM, and they normally operate with strokes from 1/8" - 1/4". The speed is inversely related to the stroke for energy limits. For example:

1/8" stroke	1300 - 1600 RPM
3/16" stroke	1200 - 1300 RPM
1/4" stroke	1000 - 1200 RPM
3/8" stroke	800 - 1000 RPM

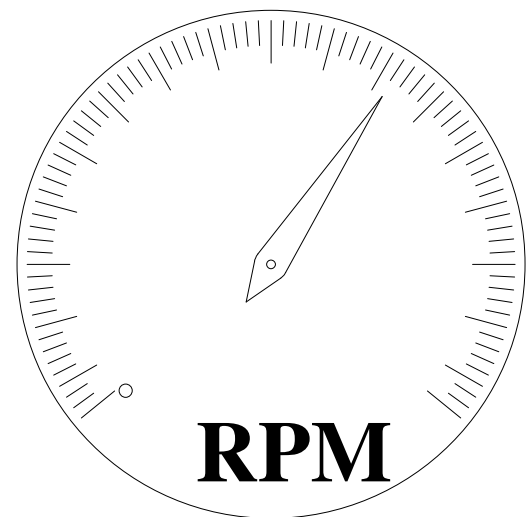

These machines should **not** be operated outside these limits. If the speed is too slow the machine will not operate at capacity. Yet if the speed is too great, the bearings will become overloaded, which results in premature bearing failure.

Generally a stroke of 3/16" and a speed of 1250 RPM is efficient in screening most materials. In other cases, a slower speed with larger stroke works well for larger size material, and faster speed with smaller stroke works well for smaller material.

Speed on a SMICO screener may be controlled in either of two ways. First, the speed can be controlled by using a variable speed motor or motor controller. Second, the speed can be changed by sheave selection. Single speed v-type sheaves are standard on SMICO screeners. These sheaves are sized to give the speed our tests and experience indicates most desirable for the job.

SCREEN CLOTH SELECTION

Screen cloth selection is very important in order to obtain proper results, to eliminate screening problems, and to avoid costly maintenance and replacement. Screen cloth should be selected by considering three aspects.

FIRST:

The first aspect is maximum open area. When the open area is maximized, the capacity and efficiency of the screen are at their peak; however, the screen life is greatly reduced, and frequent replacement will be required. The open area of a screen cloth can be increased by decreasing the wire size used in making the screen cloth.

SECOND:

The second aspect is maximum wire size. When wire size life is at its maximum, the life of the screen is increased causing less frequent screen replacement, and fewer down times. However, when wire size is at its maximum, the capacity of the screen is low. Screen life in a screen cloth can be increased by increasing the wire size used in making the screen cloth.

THIRD:

The third aspect is corrosion resistance. With a high corrosion resistant screen, the screen will hold up longer from chemical materials such as water or acid. Yet, a screen with a high corrosion resistance is costly, and may be hard to locate, and have a long delivery schedule.

The hooks on the outside edges of the screen cloth should vary depending upon the wire diameter of the screen cloth. For lighter than 16 GA cloth, the hooks need to be double bent sheet metal shrouds, to prevent the screen cloth from pulling loose when the screen cloth is tightened. Screen cloths from 16 GA to 8 GA wires need only a single fold sheet metal shroud. Wires heavier than 8 GA are strong enough to allow tensioning without any shroud.

In addition to this, specialty screens can be furnished for your particular needs. Some of these types of screens are perforated plate, slotted screens, music wire screens, flat top screens, synthetic screens, and many others. If you need further information on screen cloth selection, consult the factory.

SCREEN CLOTH REMOVAL

1. Remove feed inlet and discharge end plates.
2. Loosen the tension bolts on each side. These are the bolts holding the tension rail that stretches the screen cloth. The nuts should be backed off sufficiently to allow easy sliding of screen hooks along the tension rail. (Be sure that ALL tension bolts have been loosened.)
3. Stand at the end of the machine and slide the screen out, pulling it squarely toward you. Care should be exercised that when the screen is almost all the way out, that it is held level until it's completely out. On heavy-gauge cloth, two persons may be required.

SCREEN CLOTH INSTALLATION

1. The inside of the screen body should be thoroughly washed or wiped clean. Be sure that all surfaces are free from debris and that there are no cuttings or other foreign material caught beneath the screen when it is installed.
2. Make sure tension rails are pulled out as far as the slack in the tension bolts will allow.
3. Now insert the new screen cloth. Start one side of the screen hook strips under the tensioning rail and slip it in slightly. Start the opposite side in the same manner and with the screen square; push it into the screener.
4. The screen is in place when the hook strips on the screen are flush with each end of the screener.
5. Hand tighten the four corner tensioning nuts so that there is an equal amount of space between the hook strips and the wall of the screener on all four corners.

6. Tighten the remaining nuts hand tight.
7. Starting with the nuts in the CENTER of the tension rail and working out to the ends, slightly tighten two bolts on one side; then move to corresponding two bolts on opposite side and tighten in equal proportions. Repeat process moving from the center to the ends until screen feels tight and even.

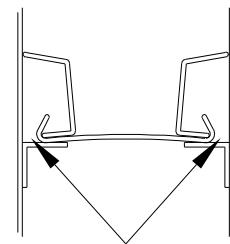

These distances must be equal

8. Check the cloth tightness by feeling the cloth for loose spots. The screen cloth must be drum head tight. Life of the screen cloth and efficiency of separation depend on there being no loose areas in the cloth. Any loose spots must be removed by tightening the tension bolts in the vicinity of the loose spot. If this does not correct the

problem, consult the factory.

9. For lighter wire screen cloth, fold down the two ends of the screen. **DO NOT CREASE.** Fold the two corners of one end and bend the cloth at the corners sharply down against the end of the screener frame. Work from either side toward the center and pull the cloth as tight as possible to further tighten at ends.
10. Replace the end plates and the unit is ready for operation. Run the screener for about 30-40 minutes. Then stop the machine and re-tighten the tension bolts. This is important since the weave of the screen will allow it to take a certain set during the first few minutes of operation and will allow slack to develop in the screen.
11. Again, re-tension after running 24 hours, as this will give greatly improved screen life.

BOLTS

All bolts on the screener are secured with lock washers or some other type of locking mechanism. After the machine has been in operation for two weeks it is wise to re-tighten the bolts to assure they are tight. Loose bolts break.

LUBRICATION

The DH1 series of screeners is a grease-lubricated drive. The recommended grease is a **lithium-based grease**, penetration class 2, with high additives and corrosion inhibitors. This **lithium based EP 2 grease** should not be blended with any other type of grease. The blending of greases of different alkylester bases is likely to result in a marked deterioration of lubricity and possible premature bearing failure.

The bearings of vibrating screens need to be re-lubricated every 50 hours of operation for normal duty operations. For higher temperature applications more frequent greasing is required. If the screener is in a hostile environment, the bearings will require more frequent re-lubrication.

The amount of grease required at each re-lubrication for the DH1 series screener drive is 1oz. The lubrication of a machine will directly affect the life of the bearing. Greasing too frequent will not harm the bearing; however, adding large quantities of grease at a time may have adverse effects.

BEARING REMOVAL

1. Disconnect the power to the motor. Tag out or lock out the motor while servicing.
2. Remove the belt guard and belt.
3. Remove the drive sheave and bushing from the shaft.
4. Remove the drive guard (Item 11).
4. Unbolt the Seal retainer (Item 5). The seal retainer is located behind the eccentric wheel.(Item 8)
5. Remove taperlock bushing(item 12). Remove the 2 set screws on either side of taperlock bushing and use one in centrally located puller hole of taperlock bushing.
6. Remove the eccentric wheel (Item 8). The eccentric wheel will slide off the bearing without hammering. NOTE: The counter weights (Item 6) do not need to be removed

to remove the counter weight wheel. **WARNING:** The eccentric wheel is heavy, use caution when removing it.

7. At this point the bearing (Item 7) is exposed.
8. Unbend the tab on the lock washer (Item 10). Remove the bearing nut (Item 9) and the lock washer from the bearing bracket (Item 1).
9. The bearing will need to be pressed off. This can be done with an appropriate sized bearing puller. NOTE: **care must be taken not to damage the bearing surface in any way.**
10. The grease seal (Item 4) is pressed into the retainer (Item 5) located behind the bearing and should be checked for cracks or wear and the seal should be replaced if necessary.

BEARING INSTALLATION

During bearing installation, cleanliness can not be over emphasized! The amount of contaminates that gets into the bearing cavity will directly effect the bearing life.

1. When purchasing a bearing it is imperative that the full part number of the Bearing be identical. **These bearings** are vibratory duty bearings and **have special clearances.**
2. Insert the seal (Item 4) into the seal retainer (Item 5). Then slip the seal assembly onto the bearing bracket (Item 1). Use a little grease around the seal to prevent the seal from getting damaged during installation.
3. Heat the bearing using a bearing heater. When the bearing is sufficiently hot, slide the bearing in place.
4. Allow the bearing to cool to a working temperature. NOTE: Cover the bearing to minimize contamination.
5. Install the bearing nut (Item 9) and washer (Item 10). Check to see that the bearing has pressed up to the shoulder in the bearing bracket (Item 1).
6. Pack the bearing with grease. Follow the bearing manufacturers recommendations when packing bearings.
7. Slide the eccentric wheel (Item 8) over the bearing (Item 7). The eccentric wheel will go over the bearing with out hammering. If it will not go over the bearing, then it is not on straight.
8. Bolt the seal retainer (Item 5) to the eccentric wheel (Item 8).
9. Reinstall taperlock bushing (Item 12).
10. Pump the grease cavity full of grease through the zerk in the eccentric wheel.
11. Install the drive cover (Item 11), and the rest of the drive components.

NOTE: **DO NOT** operate this machine without the drive cover in place. It is extremely dangerous to operate this equipment without all safety guards in place.

DH1 SERIES
SMII
312 SERIES – 85MM

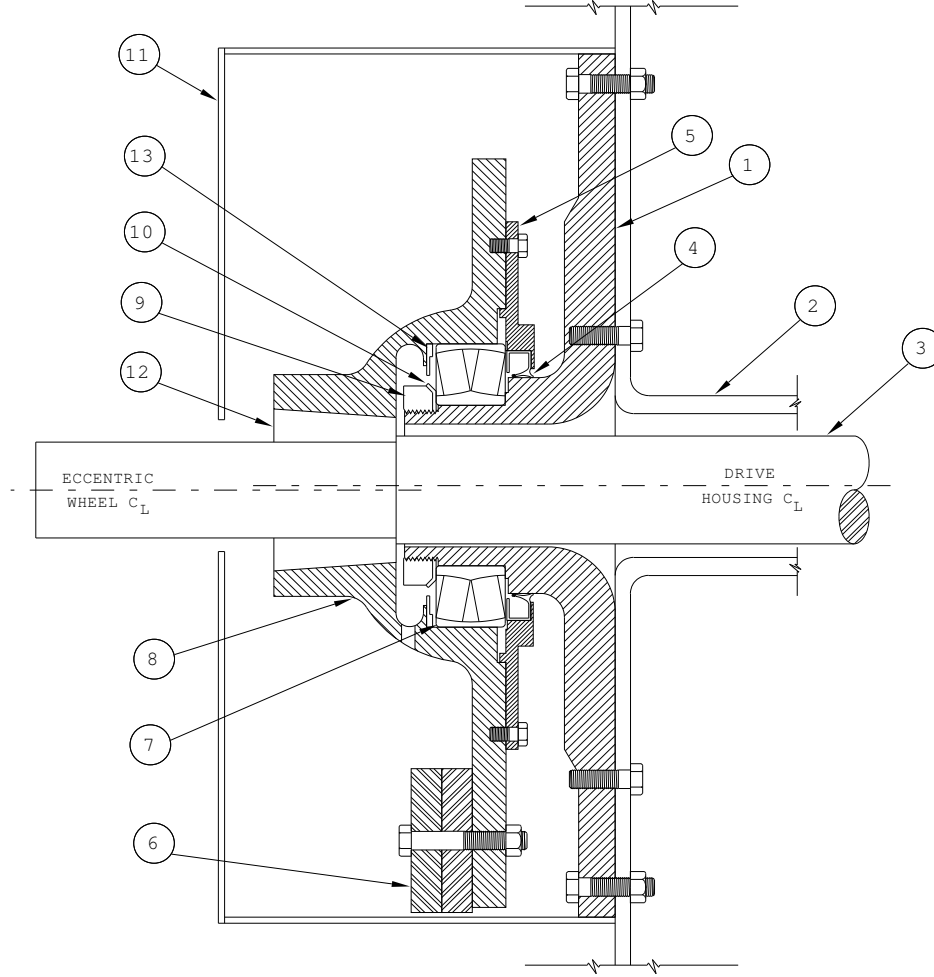

312 SERIES DRIVE PARTS LIST

ITEM	QTY	DESCRIPTION	DRAWING NO.	PART NO.	
1	2	Bearing Bracket	16976	312-303-003	(312-303-002)
2	1	Shaft Housing	23008	312-302-406	(312-302-000)
3	1	Shaft	15290	312-301-401	(312-301-000)
4	2	Seal	416153	314-200	(312-314-003)
5	2	Seal Retainer	17090	312-310-002	
6	2	Counter Weight	REF	REF	
7	2	Bearing 22217 EASM C4	22217	304-030	(312-304-001)
8	2	Eccentric Wheel .141	20062	312-306-141	(312-306-002)
9	2	Bearing Nut	W-16	318-116	(312-305-002)
10	2	Lock Washer	AN-16	318-216	(312-305-001)
11	1	Drive Guard	15870	312-309-001	
12	2	Taper lock Bushing	2525-2	346-200B	(312-305-003)
13	2	Grease Retainer	16971	312-314-002	
14	2	Grease Zerk (not shown)	16101B	312-305-004	
15	1	Drive Key (not shown)	N/A	312-305-005	
16	1	Blind /QD Bushing key(not shown)	N/A	312-305-006	
17	1	Blind Guard (not shown)	15900	312-309-002	

DH1 SERIES
5 DEUCE
314 SERIES – 110MM

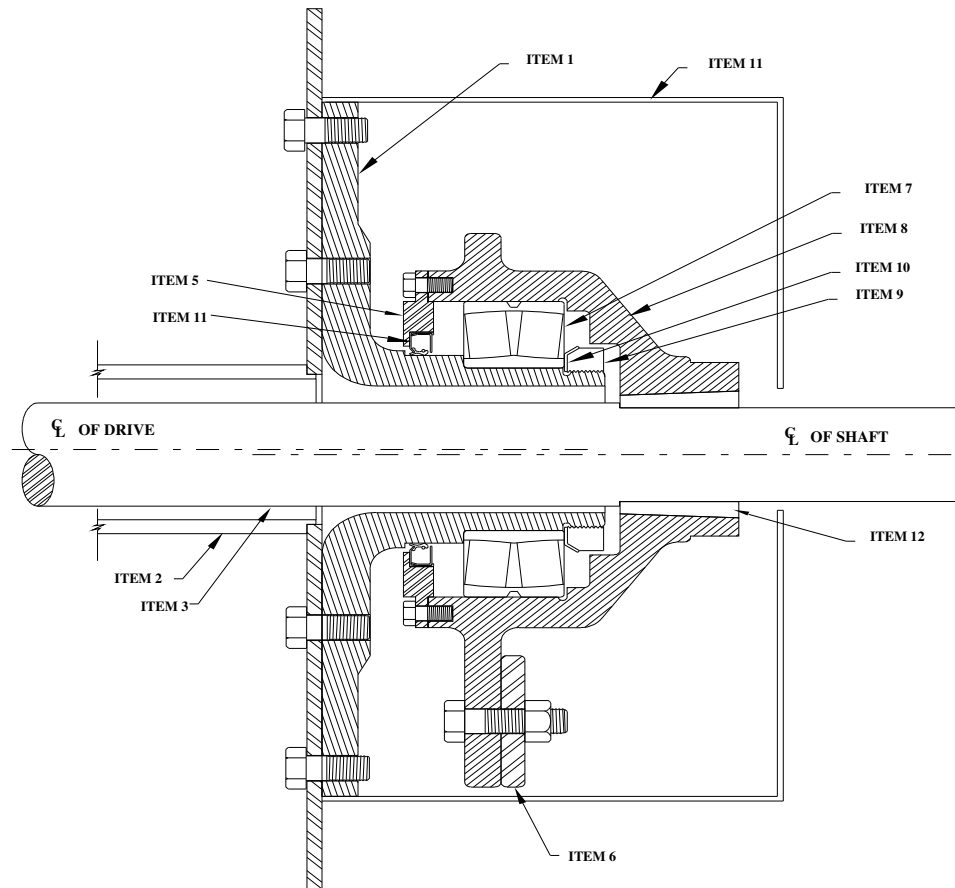

314 SERIES DRIVE PARTS LIST

ITEM	QTY	DESCRIPTION	DRAWING NO.	PARTS NO.
1	2	Bearing Bracket	18916	314-303-003
2	1	Shaft Housing	19505 OR 23804	314-302-4/506
3	1	Shaft	21077 OR 22967	314-301-501
4	2	Seal	416865	314-230
5	2	Seal Retainer/Housing	18918	314-301-002
6	2	Counter Weight	18922	REF
7	2	Bearing 22222 EASMB3	22222	304-050
8	2	Eccentric Wheel	18914	314-306-003
9	2	Bearing Nut	AN-21	318-121
10	2	Lock Washer	W-21	318-221
11	1	Drive Guard	19514 or 22083	314-309-002
12	2	Taper lock Bushing	2525 2.5	346-250
13	0	Grease Retainer	Not Used	N/A
14	2	Grease Zerk (not shown)	1610-BL	312-305-004
15	1	Drive Key (not shown)	.5-.6-2.5	314-305-005
16	1	Blind Key (not shown)		314-305-006
17	1	Blind Guard (not shown)	19515 or 22083-x	314-309-002

DH1 SERIES
315 DRIVE 22322

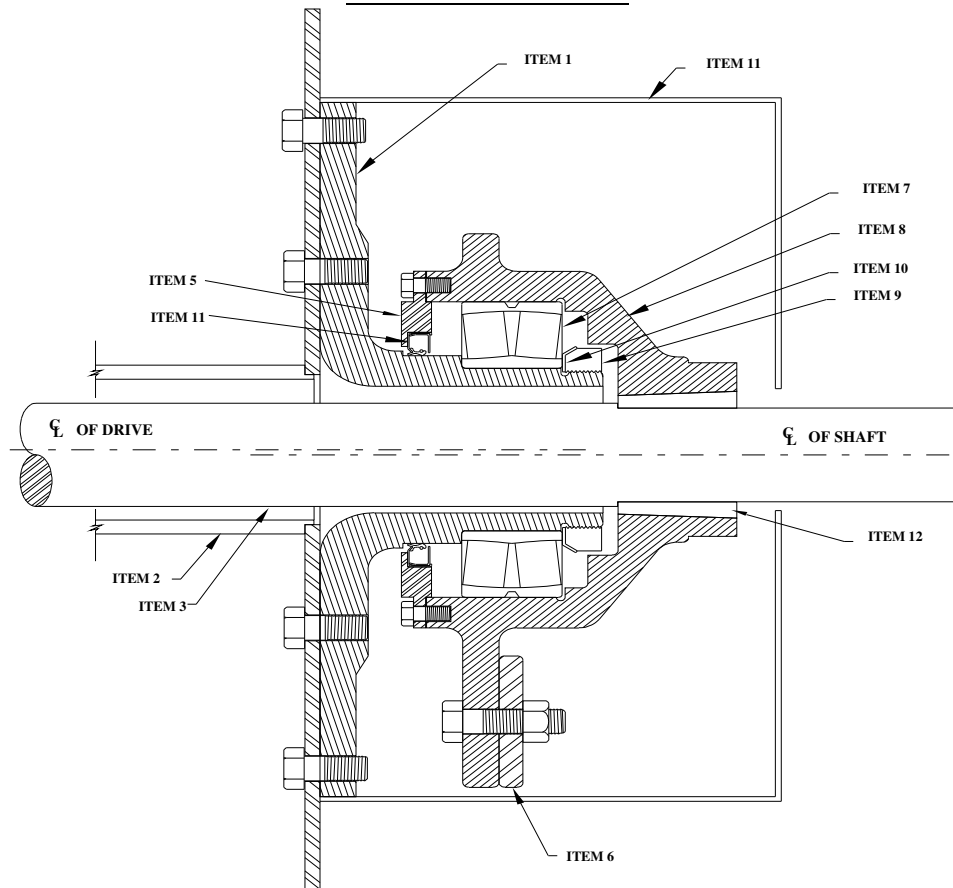

22322 DRIVE PARTS LIST

ITEM	QTY	DESCRIPTION	DRAWING NO..	PART NO.
1	2	Bearing Bracket	21266	315-303-003
2	1	Shaft Housing	21268	315-302-406
3	1	Shaft	21271	315-301-401
4	2	Seal	417541	314-230
5	2	Seal Retainer	21270	315-310-002
6	2	Counter Weight	21272	REF
7	2	Bearing	22322 EASMB3	304-030
8	2	Eccentric Wheel	21269	315-306-003/093
9	2	Bearing Nut	AN-21	318-121
10	2	Lock Washer	W-21	318-221
11	1	Drive Guard	21273	315-309-001
12	2	Taper lock Bushing	2525 2.5	346-250A
14	2	Grease Zerk (not shown)	1610-BL	315-305-004
15	1	Drive Key (not shown)	.5-.6-2.5	315-305-005
16	1	Blind Key (not shown)	315-305-006	315-305-006
17	1	Blind Guard (not shown)	21274	315-309-002

**DH1 SERIES
HEAVY DUTY
316 SERIES – 150MM**

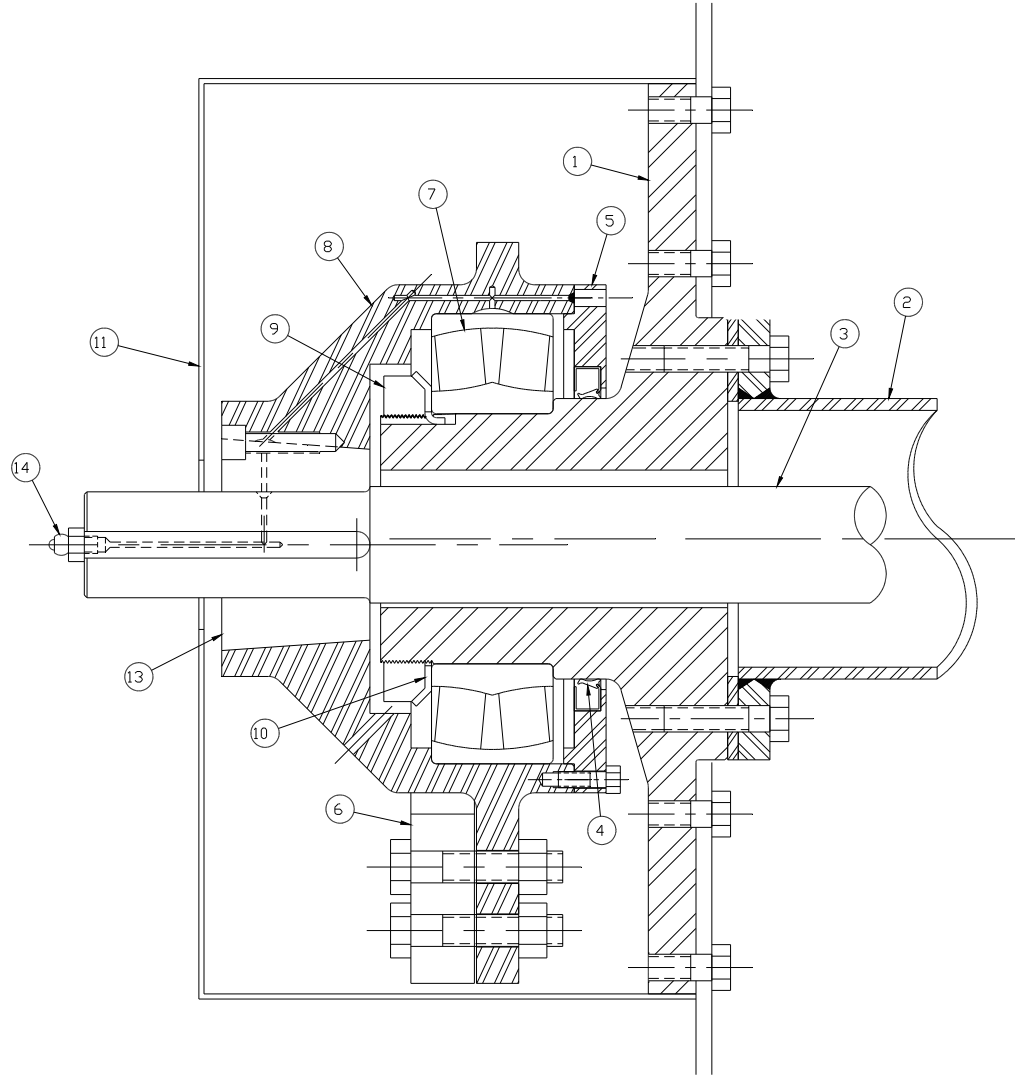

316 SERIES DRIVE PARTS LIST

ITEM	QTY	DESCRIPTION	DRAWING NO	PART NO.
1	2	Bearing Bracket	23043	316-303-060
2	1	Shaft Housing	23046	REF
3	1	Shaft	22186	REF
4	2	Seal	417298	314-260
5	2	Seal Retainer/Housing	22183	316-301-170
6	2	Counter Weight	22184	REF
7	2	Bearing 22230 EASMC3	22230	304-070
8	2	Eccentric Wheel	22181	316-306-004
9	2	Bearing Nut	AN-30	318-130
10	2	Lock Washer	W-30	318-230
11	1	Drive Guard	22253	316-309-001
12	2	Taper lock Bushing	3535-2 ½	348-250
13	0	Grease Retainer	Not Used	N/A
14	2	Grease Zerk (not shown)	1610-BL	N/A
15	1	Drive Key (not shown)	N/A	N/A
16	1	Blind Key (not shown)	N/A	N/A
17	1	Blind Guard (not shown)	19515	316-309-002